



AX7□ Series Programmable Controller Hardware User Manual



SHENZHEN INVT ELECTRIC CO., LTD.

No.	Change description	Version	Release date
1	First release.	V1.0	August 2020
2	Added content related to AX70-C-1608N, AX71-C-1608N, and AX72-C-1608N, and unified all CPU module series as AX7□ series.	V1.1	December 2022

Preface

Thank you for choosing AX7□ series programmable controller (programmable controller for short).

This guide contains the information necessary to use the programmable controller. Please read this guide carefully before using the product. Then you can fully understand the functions, performance, and system build-up, which helps to give full play to the advanced performance.

Target audience

Personnel with electrical professional knowledge (such as qualified electrical engineers or personnel with equivalent knowledge)

Applicable product

AX7□ series programmable controller CPU modules

AX7□ series programmable controller expansion modules

Online support

You can also obtain product documentation and technical support from INVT website:

<http://www.invt.com>

If the product is ultimately used for military affairs or weapon manufacture, comply with the export control regulations in the Foreign Trade Law of the People's Republic of China and complete related formalities.

The manual is subject to change without prior notice.

P1.0 Overview

Thank you for choosing the AX7□ series programmable controller and expansion modules that INVT independently develop and produce.

This manual mainly describes the hardware structure, electrical specifications, dimensions, and installation wiring of the programmable controller. Before using the programmable controller, please read this manual carefully and understand the safety precautions completely.

P2.0 Related documentation

- AX series programmable controller software user manual
- AX series programmable controller programming user manual
- AX7□ CPU module user manual
- AX-EM-1600D digital input module user manual
- AX-EM-0016DP digital output module user manual
- AX-EM-0016DN digital output module user manual
- AX-EM-4AD analog input module user manual
- AX-EM-4DA analog output module user manual
- AX-EM-4PTC temperature module user manual
- AX-EM-RCM-ET communication module user manual
- AX-PWR power supply module user manual

P3.0 EMC regulations

AX7□ series modules comply with EU EMC Directive 2014/30/EU and meet EN61121-2:2007 requirements.

P4.0 Product use flowchart

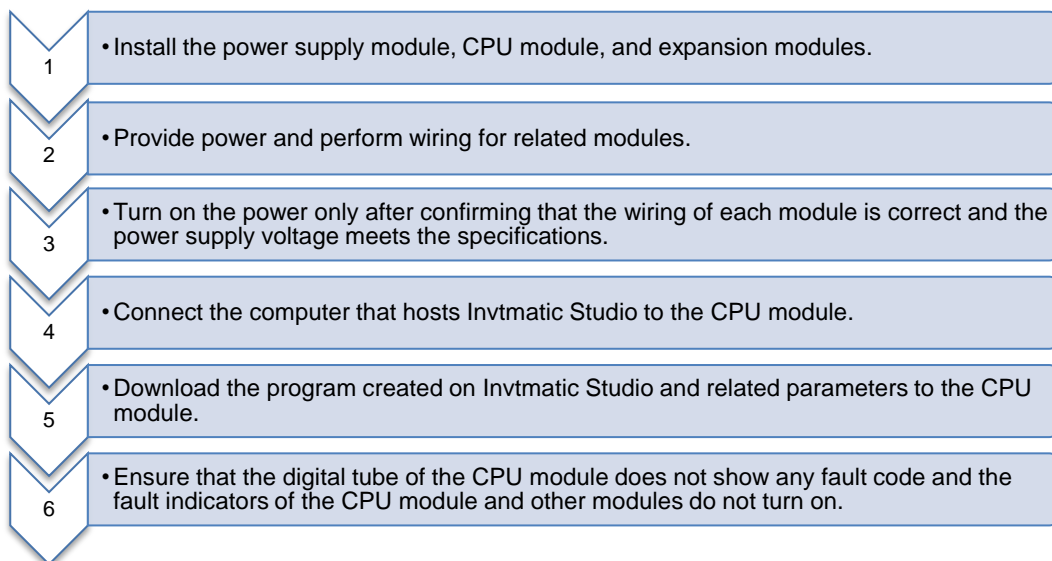

Contents

Preface	i
Target audience	i
Applicable product	i
Online support	i
P1.0 Overview	ii
P2.0 Related documentation	ii
P3.0 EMC regulations	ii
P4.0 Product use flowchart	ii
Contents	iii
1 Safety precautions	1
1.1 What this chapter contains	1
1.2 Safety definition	1
1.3 Warning	1
1.4 Safety guidelines	1
1.4.1 Delivery and installation	1
1.4.2 Wiring	2
1.4.3 Commissioning and running	3
1.4.4 Maintenance and component replacement	3
1.4.5 Disposal	4
2 Product introduction	5
2.1 What this chapter contains	5
2.2 Product overview	5
2.2.1 Product components	5
2.2.2 Product integration	8
2.3 Introduction to CPU and expansion modules	8
2.3.1 AX7□-C-1608□ CPU module	8
2.3.2 AX-EM-RCM-ET communication module	9
2.3.3 AX-EM-1600D digital input module	9
2.3.4 AX-EM-0016DP digital output module	9
2.3.5 AX-EM-0016DN digital output module	9
2.3.6 AX-EM-4AD analog input module	9
2.3.7 AX-EM-4DA analog output module	9

2.3.8 AX-EM-4PTC temperature module	10
2.4 Module model and nameplate	10
2.4.1 AX7□ series CPU module	10
2.4.2 AX-EM-1600D digital input module	10
2.4.3 AX-EM-0016DP digital output module (source type)	11
2.4.4 AX-EM-0016DN digital output module (sink type)	11
2.4.5 AX-EM-4AD analog input module	11
2.4.6 AX-EM-4DA analog output module	11
2.4.7 AX-EM-4PTC temperature module	12
2.4.8 AX-EM-RCM-ET EtherCAT communication module	12
3 Product specifications	13
3.1 Running environment	13
3.2 AX7□ series CPU module	13
3.2.1 Technical specifications	13
3.2.2 Interface description	14
3.2.3 I/O hardware specifications	15
3.3 AX-PWR power supply module	16
3.3.1 Technical specifications	16
3.3.2 Interface description	17
3.4 Expansion modules	17
3.4.1 AX-EM-1600D digital input module	17
3.4.2 AX-EM-0016DP digital output module	18
3.4.3 AX-EM-0016DN digital output module	19
3.4.4 AX-EM-4AD analog input module	20
3.4.5 AX-EM-4DA analog output module	22
3.4.6 AX-EM-4PTC temperature module	23
3.4.7 AX-EM-RCM-ET EtherCAT communication module	24
4 Product installation	27
4.1 Installation environment requirements	27
4.1.1 Installation space	27
4.1.2 Check before installation	27
4.1.3 Installation precautions	28
4.1.4 Check after installation	28
4.2 Installation method	28
4.2.1 Module installation procedure	28

4.2.2	Fixing the DIN rail to the installation plane of the control cabinet.....	29
4.2.3	Connecting the power supply module, CPU module, and expansion modules	29
4.2.4	Installing the connected modules to the DIN rail	30
4.2.5	Installing the system protection component–protective tail plate	31
4.3	Disassembling and assembling a terminal block.....	31
4.3.1	Disassembly procedure.....	31
4.3.2	Assembly procedure	31
4.4	Assembling and disassembling an SD storage card	32
4.4.1	Assembling an SD storage card.....	32
4.4.2	Disassembling an SD storage card.....	32
4.5	Replacing a module	32
5	Wiring.....	36
5.1	Wiring suggestions.....	36
5.1.1	Wiring precautions	36
5.1.2	Grounding	36
5.1.3	Installing an insulation transformer	36
5.2	Wiring the power supply module	37
5.2.1	Power supply module terminals	37
5.2.2	Wiring precautions	37
5.2.3	Grounding.....	38
5.2.4	Installing a power filter	39
5.3	Wiring AX7□-C-1608□ CPU module	39
5.3.1	High-speed I/O wiring	39
5.3.2	Communication interface wiring.....	42
5.4	Wiring expansion modules	48
5.4.1	AX-EM-1600D digital input module	48
5.4.2	AX-EM-0016DP digital output module.....	49
5.4.3	AX-EM-0016DN digital output module	50
5.4.4	AX-EM-4AD analog input module	51
5.4.5	AX-EM-4DA analog output module	53
5.4.6	AX-EM-4PT temperature module	54
5.4.7	AX-EM-RCM-ET EtherCAT communication module.....	55
6	Programming tool	57
6.1	Invtmatic Studio introduction	57
6.2	Software obtaining and installation requirements.....	57

6.3 Software installation and uninstallation	57
6.4 Connecting AX7□-C-1608□ programmable controller to a PC	61
6.5 How to use the programming software.....	61
7 Maintenance and inspection	65
7.1 Startup and shutdown	65
7.2 Indicator and SMK description	65
7.2.1 LED fault indicator.....	65
7.2.2 SMK key.....	66
7.2.3 Daily inspection.....	66
7.2.4 Periodic maintenance	66
7.3 Digital tube display of the CPU module.....	67
Appendix A Wiring examples	68
A.1 AX7□-C-1608□ high-speed I/O.....	68
A.1.1 Input wiring example of CH0–CH5	68
A.1.2 Single-ended input wiring example of CH6–CH15.....	70
A.1.3 Output wiring example	71
A.2 AX-EM-1600D digital input module	71
A.3 AX-EM-0016DP digital output module	73
A.4 AX-EM-0016DN digital output module	73

1 Safety precautions

1.1 What this chapter contains

Read this manual carefully and follow all safety precautions before moving, installing, operating and servicing the programmable controller. Otherwise, equipment damage or physical injury or death may be caused.

We shall not be liable or responsible for any equipment damage or physical injury or death caused due to your or your customers' failure to follow the safety precautions.

1.2 Safety definition

Danger: Severe personal injury or even death can result if related requirements are not followed.





Warning: Personal injury or equipment damage can result if related requirements are not followed.

Note: Actions taken to ensure proper running.



Trained and qualified professionals: People operating the equipment must have received professional electrical and safety training and obtained the certificates, and must be familiar with all steps and requirements of equipment installing, commissioning, running and maintaining and capable to prevent any emergencies.

1.3 Warning

Warnings caution you about conditions that can result in severe injury or death and/or equipment damage and advice on how to prevent dangers. The following table lists the warning symbols in this manual.

Symbol	Name	Description	Abbreviation
 Danger	Danger	Severe personal injury or even death can result if related requirements are not followed.	
 Warning	Warning	Personal injury or equipment damage can result if related requirements are not followed.	

1.4 Safety guidelines

	<ul style="list-style-type: none"> ✧ Only trained and qualified professionals are allowed to carry out related operations. ✧ Do not perform wiring, inspection or component replacement when power supply is applied. Ensure that all the input power supplies are disconnected before wiring and inspection.
	<ul style="list-style-type: none"> ✧ Do not modify AX7□ series programmable controller unless authorized; otherwise, fire, electric shock or other injury may result.

1.4.1 Delivery and installation

	<ul style="list-style-type: none"> ✧ Only trained and qualified professionals are allowed to perform installation, wiring, maintenance, and inspection.
---	--

	<ul style="list-style-type: none"> ◇ Do not install the programmable controller on inflammables. In addition, prevent the programmable controller from contacting or adhering to inflammables. ◇ Install the programmable controller in a lockable control cabinet of at least IP20, which prevents the personnel without electrical equipment related knowledge from touching by mistake, since the mistake may result in equipment damage or electric shock. Only personnel who have received related electrical knowledge and equipment operation training can operate the control cabinet. ◇ Do not run the programmable controller if it is damaged or incomplete. ◇ Do not contact the programmable controller with damp objects or body parts. Otherwise, electric shock may result.
--	---

Note:

- Select appropriate tools for delivery and installation to ensure a safe and proper running of the programmable controller and avoid physical injury or death.
- To ensure personal safety, take mechanical protective measures like wearing safety shoes and working uniforms.
- Protect the programmable controller against physical shock or vibration during delivery and installation.
- During installation and wiring, take measures to prevent screws, cables and other conductive matters from falling into the internal of the programmable controller so as to avoid short circuit in the programmable controller, which may cause fire, system fault, and misoperation.
- After installation, ensure that there are no obstructions on the vents of the programmable controller; otherwise, the chips of the programmable controller may be burned due to overheating and poor heat dissipation, which causes system control failure and misoperation.
- During installation, ensure that the modules are tightly connected and fastened. Unsecure connection may cause communication failure and fall-off.

1.4.2 Wiring

	<ul style="list-style-type: none"> ◇ Only trained and qualified professionals are allowed to perform installation, wiring, maintenance, and inspection. ◇ Fully understand the interface types, specifications, and related requirements before wiring. Otherwise, incorrect wiring will cause abnormal running. ◇ Cut off all power supplies connected to the programmable controller before performing wiring. ◇ Before power-on for running, ensure that each module terminal cover is properly installed in place after the installation and wiring are completed. This prevents a live terminal from being touched. Otherwise, physical injury, equipment fault or misoperation may result. ◇ Install proper protection components or devices when using external power supplies for the programmable controller. This prevents the programmable controller from being damaged due to external power supply faults, overvoltage, overcurrent, or other exceptions.
---	--

Note:

- During wiring, prevent metal fragments, cables and other conductive matters from falling into the internal of the programmable controller through the vents so as to avoid internal short circuit and poor heat dissipation.
- The specifications of cables used for wiring must meet relevant interface specifications and standards.
- To ensure personal safety and equipment use safety, reliably ground the programmable controller using cables with

proper diameters and specifications.

- Route the control signal and communication signal cables separately from cables with strong interference such as power cables.
- Apply fastening means to long-distance or heavy cables.

1.4.3 Commissioning and running

	<ul style="list-style-type: none"> ◇ Before power-on for running, ensure that the working environment of the programmable controller meets the requirements, the wiring is correct, the input power specifications meet the requirements, and a protection circuit has been designed to protect the programmable controller so that the programmable controller can run safely even if an external device fault occurs. ◇ For modules or terminals requiring external power supply, configure external safety devices such as fuses or circuit breakers to prevent damage caused due to external power supply or device faults.
---	---

Note:

- In the external circuit of the programmable controller, configure an emergency braking circuit, a protection circuit, a circuit for interlocking between forward and reverse operations, and an anti-equipment-damage switch for interlocking between the position upper limit and lower limit.
- To ensure the safe running of equipment, design external protection circuits and safety mechanisms for output signals related to major accidents.
- Design proper external control circuits to ensure the proper running of equipment, since all outputs are turned off when the CPU module detects an exception and outputs may be out of control when the control circuit has an exception.
- When the output units such as relays and transistors of any modules of the programmable controller are damaged, the output cannot be controlled to be On or Off as configured.
- Ensure that the power supply system of the programmable controller has lightning protection devices to prevent lightning overvoltage from being applied to the power input or signal I/O terminals of the programmable controller so as to avoid equipment damage, since the programmable controller is designed to be used in the indoor environment of overvoltage level II.



1.4.4 Maintenance and component replacement

	<ul style="list-style-type: none"> ◇ Only trained and qualified professionals are allowed to perform maintenance, inspection, and component replacement for the programmable controller. ◇ Cut off all power supplies connected to the programmable controller before terminal wiring. ◇ During maintenance and component replacement, take measures to prevent screws, cables and other conductive matters from falling into the internal of the programmable controller.
---	---

Note:

- Use proper torque to tighten screws.
- During maintenance and component replacement, keep the programmable controller and its parts and components away from combustible materials and ensure they have no combustible materials adhered.
- During maintenance and component replacement, take proper anti-static measures on the programmable controller and its internal parts.

1.4.5 Disposal

	◇ The programmable controller contains heavy metals. Dispose of a scrap programmable controller as industrial waste.
	◇ Dispose of a scrap programmable controller separately at an appropriate collection point but not place it in the normal waste stream.

2 Product introduction

2.1 What this chapter contains

This chapter describes what the programmable controller consists of, helping the understanding and quick use of the programmable controller.

2.2 Product overview

2.2.1 Product components

The programmable controller must at least consist of:

- Power supply module
Mandatory for local and remote modules. The power supply module can convert AC power to DC power and output the power to other modules on the rail.



Figure 2.1 Power supply module

- CPU module
As the core control module of the programmable controller, the CPU module implements the control, monitoring, data processing, and networking communication for the system running. Currently, CPU modules are divided into two types: AX7□-C-1608P and AX7□-C-1608N, which support the same interface communication protocol, only with different interface modes. This manual often takes AX70-C-1608P or AX71-C-1608N for example.



Figure 2.2 AX7□-C-1608P CPU module

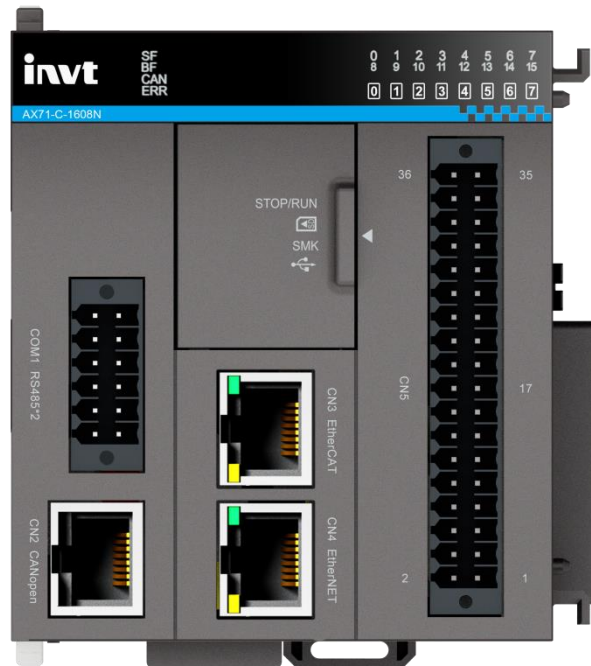

Figure 2.3 AX7□-C-1608N CPU module

- DIN rail

The programmable controller uses modular design, with the power supply module, CPU module, and other expansion modules installed on the DIN rail and fixed to respective positions.

In addition to these mandatory modules, you can choose different expansion modules to build a local or remote control system according to your needs.

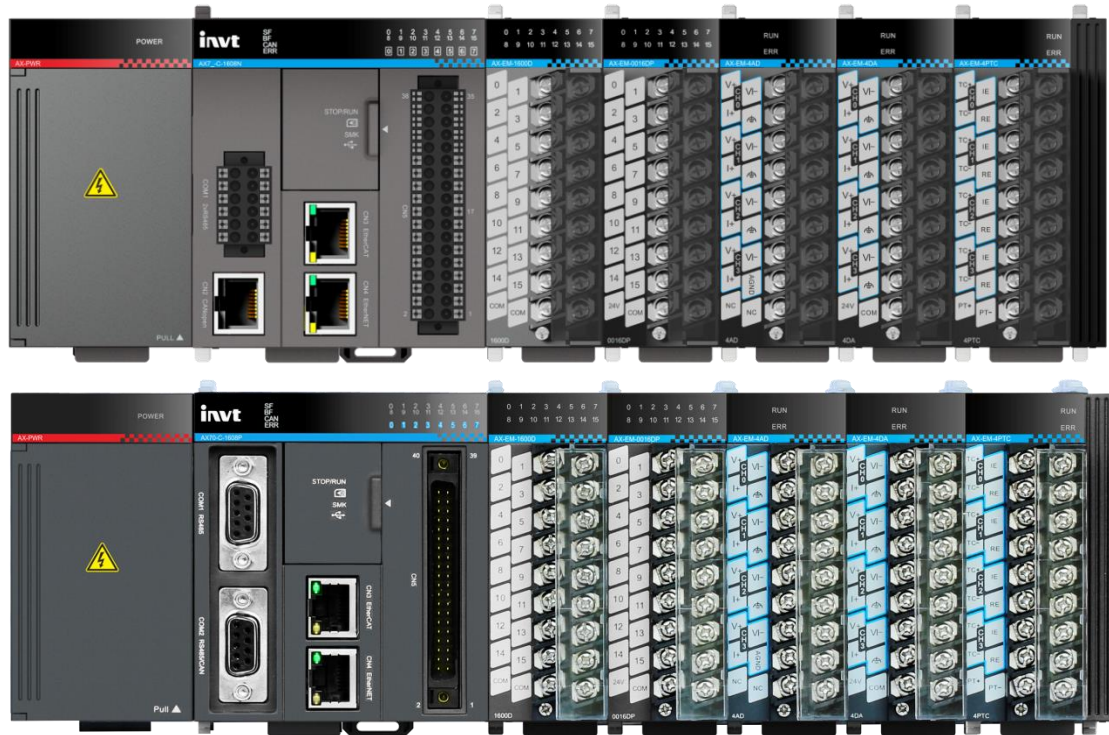
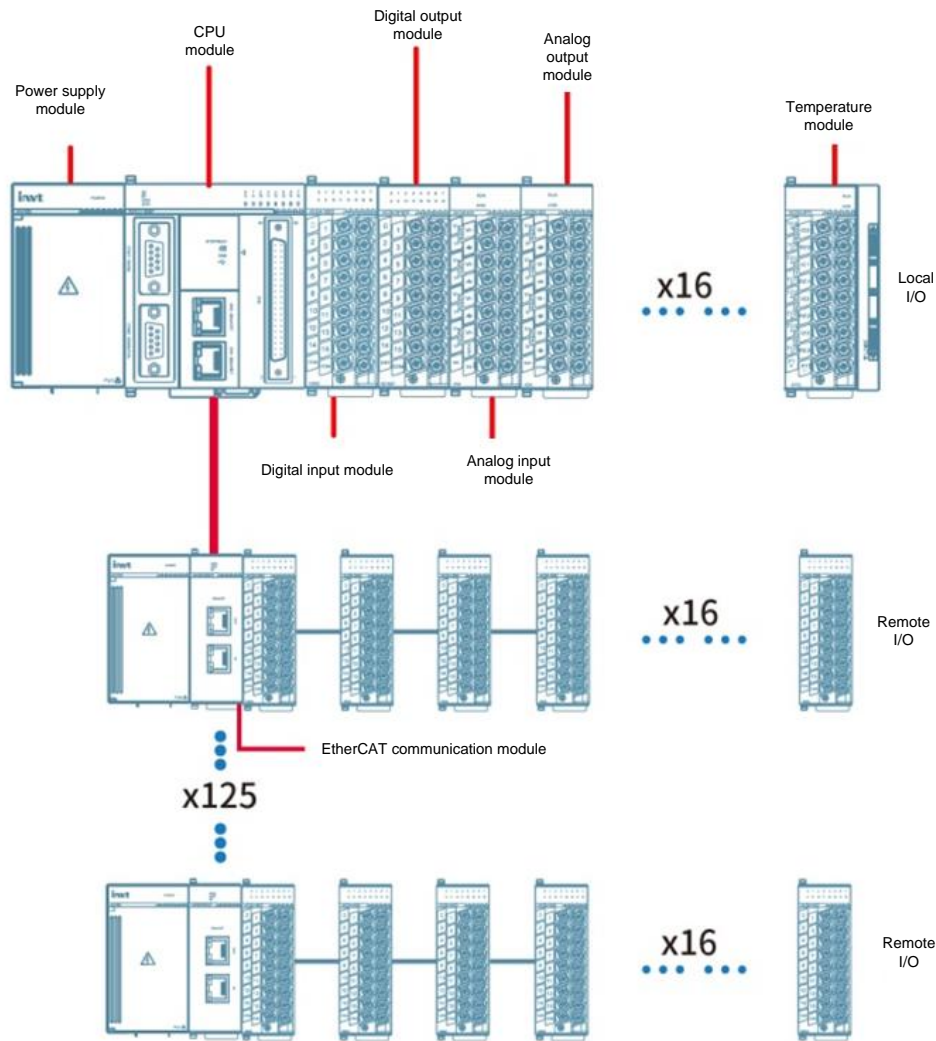

Figure 2.4 Assembly of programmable controller components

2.2.2 Product integration



2.3 Introduction to CPU and expansion modules

2.3.1 AX7□-C-1608□ CPU module

As the main control module of the programmable controller, AX7□-C-1608□ CPU module (CPU module for short) has the following functions:

- Realizes the control, monitoring, data processing, and networking communication for the system running.
- Uses Invtmatic Studio that INVT has launched for programming, and supports the IL, ST, FBD, LD, CFC, and SFC programming languages compliant with IEC61131-3 standards.
- Supports 16 local expansion modules (such as the I/O, temperature, and analog modules).
- Uses EtherCAT or CANopen bus to connect slave modules, each of which supports 16 expansion modules (such as the I/O, temperature, and analog modules).
- Supports Modbus TCP master/slave protocol.
- Integrates two RS485 interfaces, supporting Modbus RTU master/slave protocol.
- Supports high-speed I/O, 16 high-speed inputs and 8 high-speed outputs.

- Supports EtherCAT fieldbus motion control on a maximum of 32 axes with synchronization time of 1ms, 2ms, 4ms, or 8ms.
- Supports pulse single- or multi-axis motion control, 2–4 axis linear interpolation, and 2-axis arc interpolation.
- Supports real-time clock.
- Supports power-failure data protection.

2.3.2 AX-EM-RCM-ET communication module

As the EtherCAT communication module of the programmable controller, AX-EM-RCM-ET module has the following functions:

- Reaches the Ethernet communication rate of 100Mbps, with the communication distance within 100m.
- Supports the expansion up to 125 EtherCAT slave nodes.
- Each slave node supports the connection to 16 I/O expansion modules.

2.3.3 AX-EM-1600D digital input module

As the digital input expansion module of the programmable controller, AX-EM-1600D module has the following functions:

- Supports 16 channels of digital input.
- Supports the voltage input of the source and sink types, with the max. input voltage up to 30V.

2.3.4 AX-EM-0016DP digital output module

As the digital output expansion module of the programmable controller, AX-EM-0016DP has the following functions:

- Supports 16 channels of digital output of the source transistor type.
- Allows the max. current at the common terminal up to 2A and supports short circuit protection.

2.3.5 AX-EM-0016DN digital output module

As the digital output expansion module of the programmable controller, AX-EM-0016DN has the following functions:

- Supports 16 channels of digital output of the sink transistor type.
- Allows the max. current at the common terminal up to 2A and supports short circuit protection.

2.3.6 AX-EM-4AD analog input module

As the analog input expansion module of the programmable controller, AX-EM-4AD module has the following functions:

- Supports 4 channels of voltage and current input.
- Input voltage range: bipolarity $\pm 5V$ and $\pm 10V$; unipolarity $+5V$ and $+10V$
- Input current range: $-20mA$ – $+20mA$, $0mA$ – $20mA$, $4mA$ – $20mA$
- Input current and voltage detection accuracy: 0.1%
- With a 24-bit resolution
- Support upgrade through serial ports.

2.3.7 AX-EM-4DA analog output module

As the analog output expansion module of the programmable controller, AX-EM-4DA module has the following functions:

- Supports 4 channels of voltage and current input.

- Voltage output range: For polarity, ±5V and ±10V; for unipolarity, +5V and +10V. Driven load range: 1kΩ–1MΩ
- Current output range: 4mA–20mA, 0mA–20mA. Driven road range: 0–1kΩ
- Voltage or current output accuracy at room temperature: 0.1%
- With a 16-bit resolution
- Supports voltage short circuit and current open-circuit detection.
- Support upgrade through serial ports.

2.3.8 AX-EM-4PTC temperature module

As the temperature measuring module of the programmable controller, AX-EM-4PTC module has the following functions:

- Supports 4 channels of sensor input.
- Each channel of the module supports various thermocouples (TCs) and resistance temperature detectors (RTDs) (allowing 2-, 3-, and 4-wire systems).
- For RTDs: Full measuring range ± 0.1%, ± 1°C
For TCs: Full measuring range ± 0.3%
- With a 24-bit resolution
- Supports internal and external cold junction compensation for TC measuring.

2.4 Module model and nameplate

2.4.1 AX7□ series CPU module

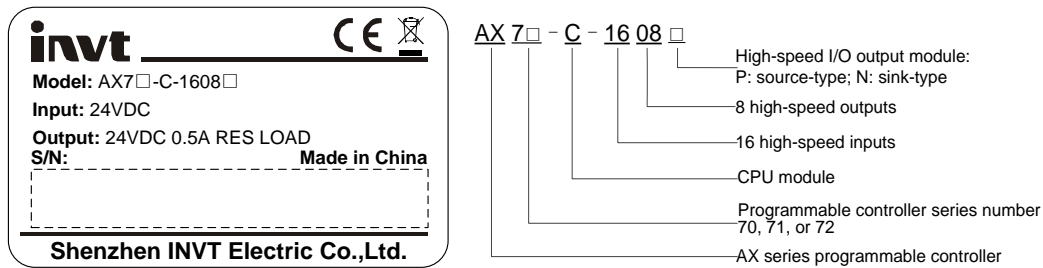

Figure 2.5 AX7□ series CPU module

2.4.2 AX-EM-1600D digital input module

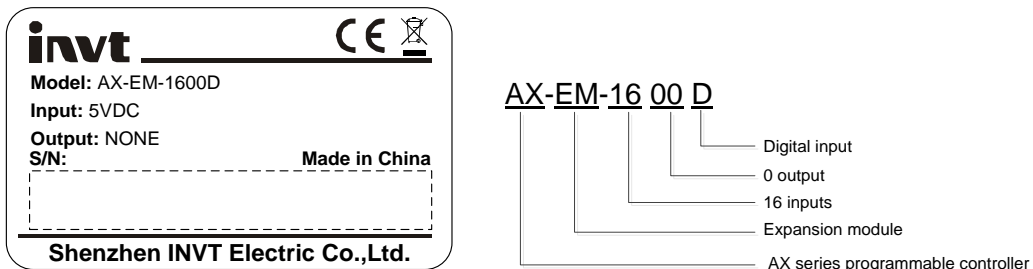

Figure 2.6 AX-EM-1600D digital input module

2.4.3 AX-EM-0016DP digital output module (source type)

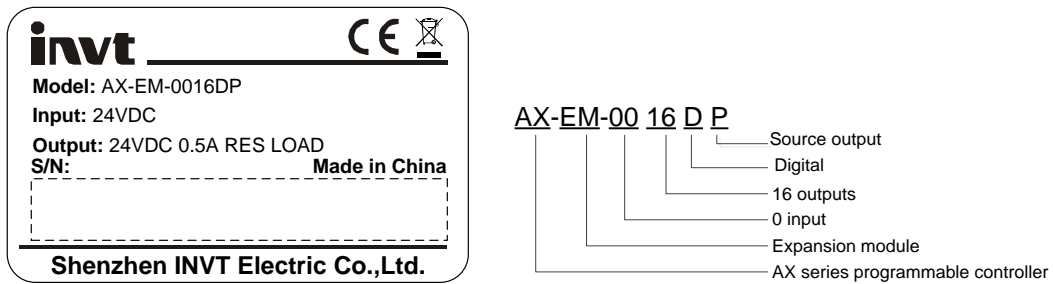
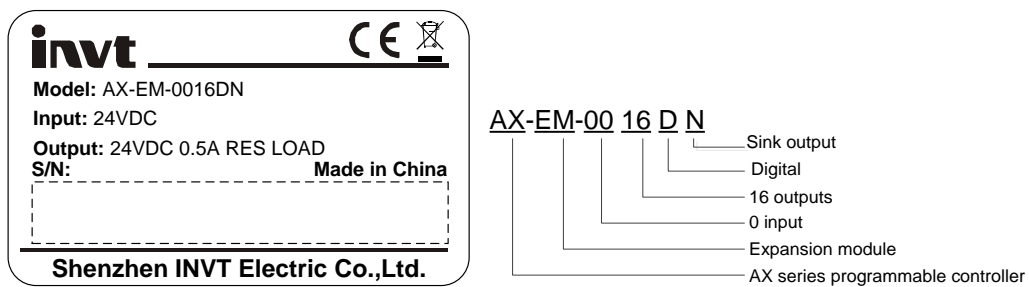

Figure 2.7 AX-EM-0016DP digital output module (source type)

2.4.4 AX-EM-0016DN digital output module (sink type)



2.4.5 AX-EM-4AD analog input module

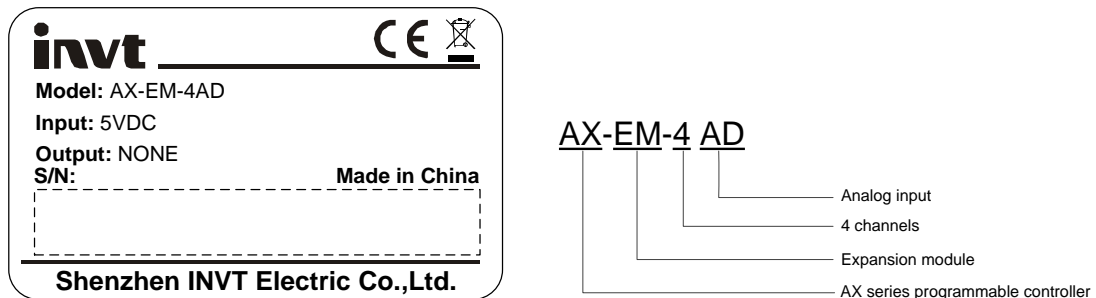

Figure 2.8 AX-EM-4AD analog input module

2.4.6 AX-EM-4DA analog output module

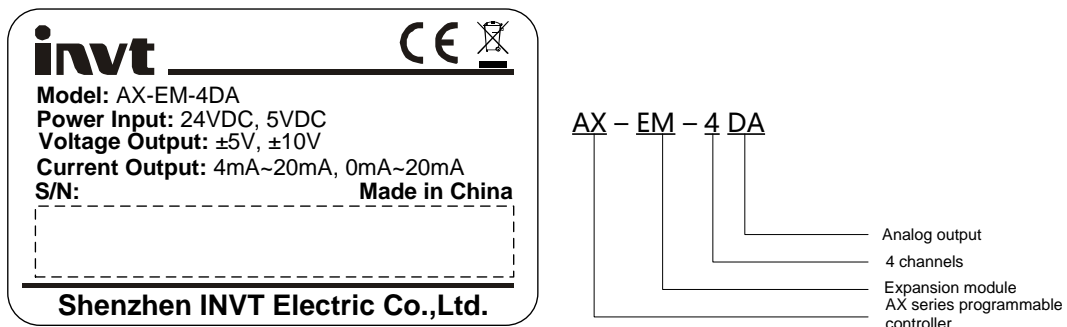

Figure 2.9 AX-EM-4DA analog output module

2.4.7 AX-EM-4PTC temperature module

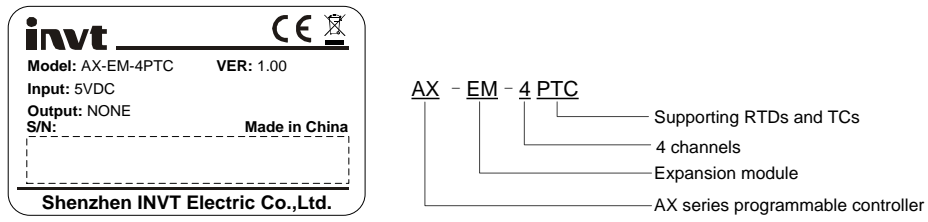

Figure 2.10 AX-EM-4PTC temperature module

2.4.8 AX-EM-RCM-ET EtherCAT communication module

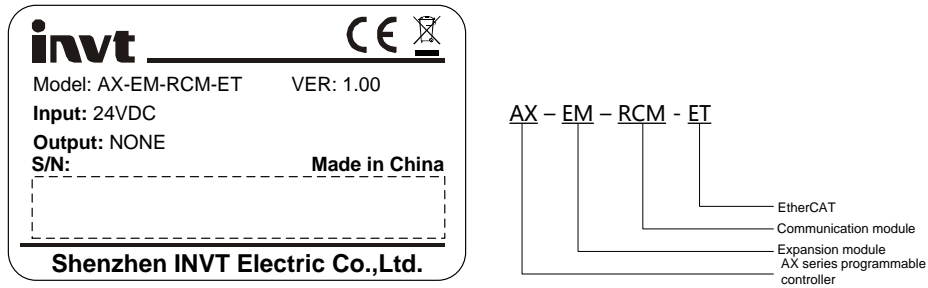

Figure 2.11 AX-EM-RCM-ET EtherCAT communication module

3 Product specifications

3.1 Running environment

Item	Specifications
Running environment	Indoor control cabinet, no corrosive gas
Running environment temperature	-5°C – +55°C
Storage temperature	-25°C – +70°C
Running environment humidity	10%–95%, no condensation
Random vibration	10Hz–500Hz, 0.01gn ² /Hz, 30min/axis, axes X/Y/Z
Sinusoidal vibration	5Hz–8.4Hz, vibration amplitude of 3.5mm; 8.4Hz–150Hz, acceleration of 10m/s ² ; X/Y/Z axis, 10cycles
Mechanical shock	Pulse shock way: Half-sine wave; acceleration: 150m/s ² ; duration: 11ms; for axes X/Y/Z, 3 times for forward direction and 3 times for reverse direction for each axis, a total of 18 times
Random vibration for package	10Hz–100Hz, 0.05gn ² /Hz, 100Hz–200Hz, -7dB/Oct, 30min/axis, axes X/Y/Z

3.2 AX7□ series CPU module

3.2.1 Technical specifications

Item	Description																											
Input voltage	24VDC																											
Power	<15W																											
Power-failure protection time	300ms (no protection within 20 seconds after power-on)																											
Backup battery of the real-time clock	Included																											
Backplane bus power supply	5V/2.5A																											
Programming method	IEC 61131-3 programming languages (LD, FBD, IL, ST, SFC, and CFC)																											
Program execution method	Local online																											
User program storage space	4MB																											
Flash memory space for power failure protection	512KB																											
SD card specifications	32G MicroSD																											
Soft elements and characteristics	<table border="1"> <thead> <tr> <th rowspan="2">Element</th> <th rowspan="2">Name</th> <th rowspan="2">Count</th> <th colspan="3">Storage characteristics</th> </tr> <tr> <th>Default</th> <th>Writable</th> <th>Description</th> </tr> </thead> <tbody> <tr> <td>I</td> <td>Input relay</td> <td>64KWord</td> <td>Not save</td> <td>No</td> <td>X: 1 bit</td> </tr> <tr> <td>Q</td> <td>Output relay</td> <td>64KWord</td> <td>Not save</td> <td>No</td> <td>B: 8 bits W: 16 bits</td> </tr> <tr> <td>M</td> <td>Auxiliary output</td> <td>128KWord</td> <td>Save</td> <td>Yes</td> <td>D: 32 bits L: 64 bits</td> </tr> </tbody> </table>	Element	Name	Count	Storage characteristics			Default	Writable	Description	I	Input relay	64KWord	Not save	No	X: 1 bit	Q	Output relay	64KWord	Not save	No	B: 8 bits W: 16 bits	M	Auxiliary output	128KWord	Save	Yes	D: 32 bits L: 64 bits
	Element				Name	Count	Storage characteristics																					
		Default	Writable	Description																								
	I	Input relay	64KWord	Not save	No	X: 1 bit																						
Q	Output relay	64KWord	Not save	No	B: 8 bits W: 16 bits																							
M	Auxiliary output	128KWord	Save	Yes	D: 32 bits L: 64 bits																							
Program retention	Retention by the internal flash																											

Item	Description
method upon power failure	
Interruption mode	External interruption (8, with the rising/falling edge configurable); probe interruption (4, with the rising/falling edge configurable); consistency comparison interruption (8)

3.2.2 Interface description

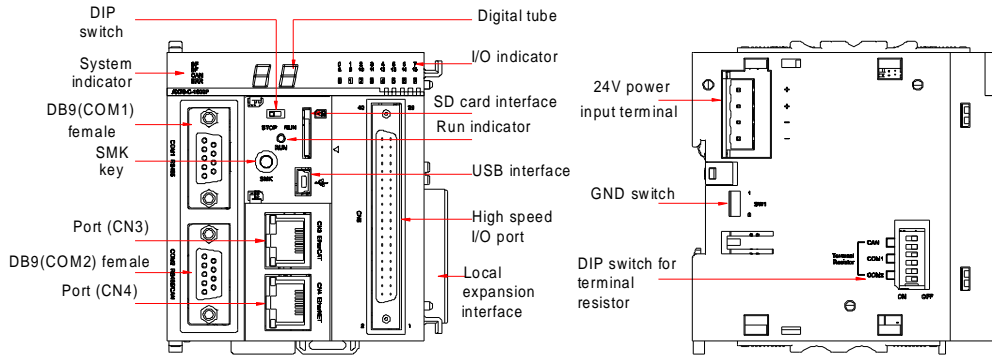

Figure 3.1 External interfaces of AX7□-C-1608P CPU module

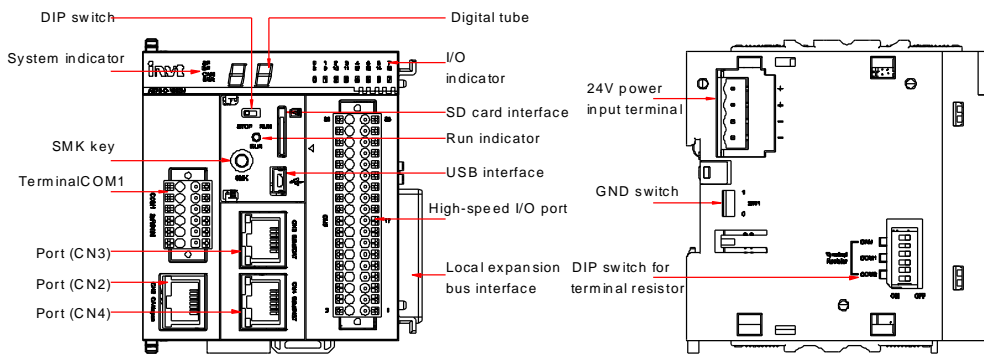

Figure 3.2 External interfaces of AX7□-C-1608N CPU module

Table 3.1 External interfaces of the CPU module

Interface		Function
DIP switch		RUN/STOP DIP switch.
System indicator		SF: System fault indicator. BF: Bus fault indicator. CAN: CAN bus fault indicator. ERR: Module fault indicator.
SMK key		SMK smart key.
AX7□ -C-1608P	DB9 (COM1) female	One RS485 interface, supporting Modbus RTU master/slave protocol.
	DB9 (COM2) female	One RS485 interface, and the other CAN interface. The RS485 interface supports Modbus RTU master/slave protocol and the other CAN interface supports CANopen master/slave protocol
AX7□ -C-1608N	COM1 and COM 2 (In-line)	Two R485 interfaces, supporting Modbus RTU master/slave protocol

Interface		Function
	terminal)	
	CN2 (RJ45)	CAN interface, supporting CANopen master/slave protocol
CN3 (RJ45)		EtherCAT interface.
CN4 (RJ45)		<ul style="list-style-type: none"> • Ethernet interface • Standard Ethernet functions compliant with Modbus TCP protocol • User program download and debug (only with IPv4)
Digital tube		Displays alarms and replies to SMK key pressing.
I/O indicator		Indicates whether the signals of 16 inputs and 8 outputs are valid.
SD card interface		Used to store user programs and data.
Run indicator		Indicates whether the CPU module is running.
USB interface		Used to download and debug programs.
High-speed I/O interface		16 high-speed inputs and 8 high-speed outputs.
Local expansion interface		Supports the expansion of 16 I/O modules, disallowing hot swapping.
24V power interface		DC 24V voltage input.
Grounding switch		Connection switch between the system internal digital ground and housing ground. It is disconnected by default (SW1 is set to 0). It is used only in special scenarios where the system internal digital ground is taken as the reference plane. Exercise caution before operating it. Otherwise, system stability is impacted.
DIP switch of terminal resistor		ON indicates terminal resistor connection (it is OFF by default). Among the silkscreens, COM1 corresponds to RS485-1, COM2 to RS485-2, and CAN to CAN.

3.2.3 I/O hardware specifications

Table 3.2 Input specifications

Item	Specifications	
Signal name	High-speed differential input	High-speed single-end input
Rated input voltage	$2.5V < V_{IN+} - V_{IN-} < 6V$	24VDC (+20% – -15%, pulsating within 5%)
Rated input current	6.8mA	5.7mA (Typical value) (at 24VDC)
ON current	/	More than 2mA
OFF current	/	Less than 1mA
Input resistance	540Ω	2.2kΩ
Max. counting speed	800K Pulse/s (2PH fourfold frequency), 200kHz (single channel of input)	
2PH input duty ratio	40%: 60%	
Common terminal	/	One common terminal is used.

Table 3.3 Output specifications

Item	Specifications
Signal name	Output (Y0–Y7)
Output polarity	AX7□-C-1608P: source output (active high) AX7□-C-1608N: sink output (active low)
Control circuit voltage	DC 5V–24V

Item	Specifications
Rated load current	100mA/point, 1A/COM
Max. voltage drop at ON	0.2V (Typical value)
Leakage current at OFF	Less than 0.1mA
Output frequency	200kHz (The output of 200kHz requires the externally connected equivalent load must be greater than 12mA.)
Common terminal	Eight points use one common terminal.

Note:

- The total length of high-speed I/O port connection cable cannot exceed 3 meters.
- Do not bend the cables when fastening the cables.
- During cable routing, separate the connection cables from high-power cables that cause strong interference but not bind the connection cables with the latter together. In addition, avoid long-distance parallel routing.

3.3 AX-PWR power supply module

3.3.1 Technical specifications

Table 3.4 General specifications

Item	Specifications
Input power	100–240VAC (-15% – +10%)
Input frequency	50/60Hz (-5% – +5%)
Output voltage	24VDC ± 5%
Rated output current	2A
Efficiency	> 70%
Overcurrent protection	Included
Fuse	Built in

Table 3.5 Electrical specifications

Item	Name	Rating	Test condition	Remarks
Insulation resistance	Primary side–SELV	≥ 2 x 106Ω	Ambient temperature: 25±5°C; relative humidity: < 90% (no condensation); test voltage: 500VDC	Depends on customer requirements
	Primary side–PE	≥ 2 x 106Ω		
Withstand voltage	Reinforced insulation	Primary side–SELV: 3250VDC (2300VAC), 1 minute		No arc or breakdown, leakage current less than 10mA
	Basic insulation	Primary side–PE (or grounding housing): 1900VDC (1350VAC), 1 minute		
Pulse	Reinforced insulation	Primary side–SELV: 4250V pulses		No arc or breakdown
	Basic insulation	Primary side–PE (or grounding housing): 2500V pulses		
Rated input voltage range	AC input	100–240VAC		-
Rated input current		Up to 2A		-

Item	Name	Rating	Test condition	Remarks
IP rating		IP20		-
Pollution degree		PD2		-
Altitude		2000M (80kPa)		-
Overtoltage class		Pluggable or fixed device that draws electricity from an indoor socket		-
Max. working temperature		55°C in full load		-
Overcurrent protection device		Fuse		-

3.3.2 Interface description

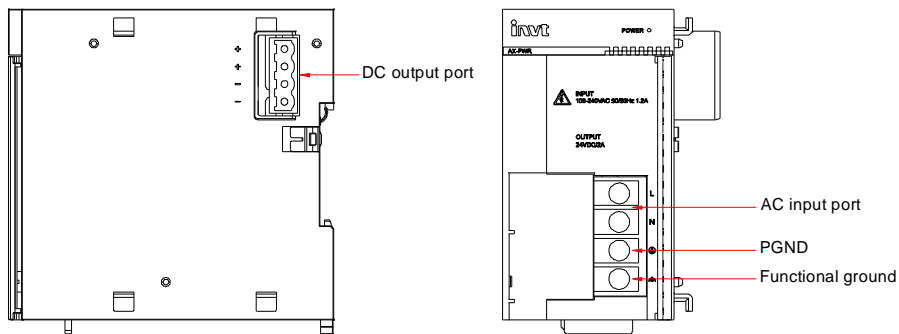

Figure 3.3 External interfaces of the power supply module

Table 3.6 External interfaces of the power supply module

Interface	Symbol	Function
Input port		
AC input	L, N	100VAC~240VAC input
Protection ground	⊕	Connects to AC input power ground wire.
Function ground	⊕	Connects to the system housing.
Output port		
+24V	+	+24V DC output
GND	-	DC output ground

3.4 Expansion modules

3.4.1 AX-EM-1600D digital input module

3.4.1.1 Specifications

Table 3.7 Power supply requirement

Item	Range
Power supply voltage	Internally powered, 5VDC (-10% – +10%)

Table 3.8 Performance parameters

Item	Specifications
Input channel	16
Input connection method	18-point wiring terminals
Input voltage class	24V (up to 30V)
Input current (typical)	4.7mA
ON voltage	> 15VDC
OFF voltage	< 5VDC
Port filter time	10ms
Input resistance	5.4kΩ
Input signal type	Voltage DC input
Isolation method	Optocoupler
Input dynamic display	The indicator is on when input is valid.

3.4.1.2 Interface description

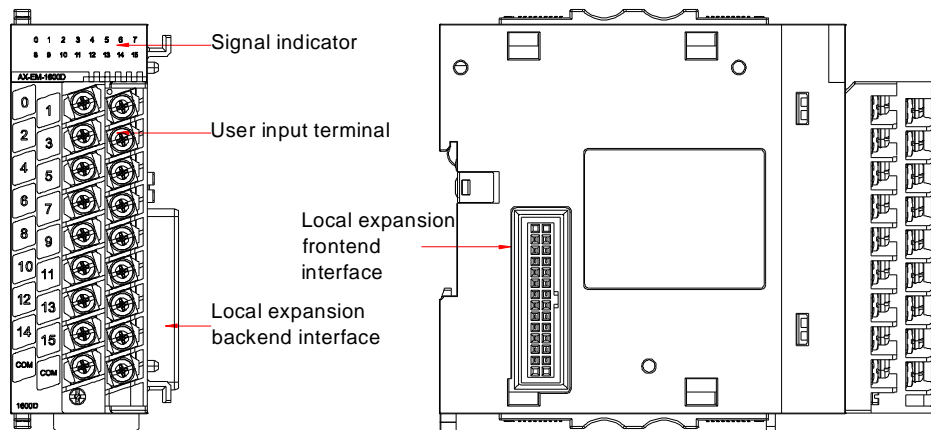

Figure 3.4 External interfaces of the digital input module

Table 3.9 External interfaces of the digital input module

Interface	Function
Indicator	Each corresponds to a channel of input signal. An indicator is on when the input is valid, and it is off when the input is invalid.
User input terminal	16 inputs
Local expansion frontend interface	Connects to frontend modules, disallowing hot swapping.
Local expansion backend interface	Connects to backend modules, disallowing hot swapping.

3.4.2 AX-EM-0016DP digital output module

3.4.2.1 Specifications

Table 3.10 Power supply requirement

Item	Range
Power supply voltage	Internally powered, 5VDC (-10% – +10%)
Voltage of external 24V	24VDC (-15% – +5%)

Table 3.11 Performance parameters

Item	Specifications
Output channel	16
Output connection method	18-point wiring terminals
Output type	Source output, active high
Power supply voltage	24VDC (-15% – +5%)
Output voltage class	12V–24V (-15% – +5%)
ON response time	< 0.5ms
OFF response time	< 0.5ms
Max. load	0.5A/point; 2A/common terminal (resistive load)
Isolation method	Magnetic
Output action display	The output indicator is on.
Short-circuit protection output	Supported

3.4.2.2 Interface description

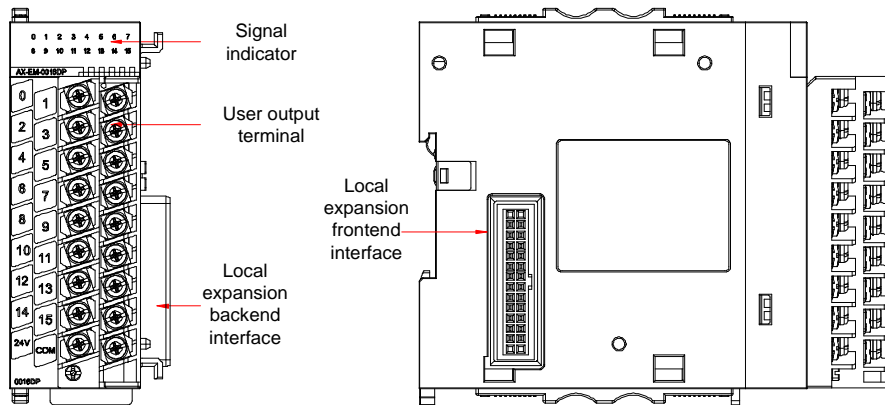

Figure 3.5 External interfaces of the digital output module

Table 3.12 Digital output module interface description

Interface	Function
Signal indicator	Each corresponds to a channel of output signal. An indicator is on when the output is valid, and it is off when the output is invalid.
User output terminal	16 outputs
Local expansion frontend interface	Connects to frontend modules, disallowing hot swapping.
Local expansion backend interface	Connects to backend modules, disallowing hot swapping.

3.4.3 AX-EM-0016DN digital output module

3.4.3.1 Specifications

Table 3.13 Power supply requirement

Item	Range
Power supply voltage	Internally powered, 5VDC (-10% – +10%)
Voltage of external 24V	24VDC (-15% – +5%)

Table 3.14 Performance parameters

Item	Specifications
Output channel	16
Output connection method	18-point wiring terminals
Output type	Sink output
Power supply voltage	24VDC (-15% – +5%)
Output voltage class	12V–24V (-15% – +5%)
ON response time	< 0.5ms
OFF response time	< 0.5ms
Max. load	0.5A/point; 2A/common terminal (resistive load)
Isolation method	Magnetic
Output action display	The output indicator is on.
Short-circuit protection output	Supported

3.4.3.2 Interface description

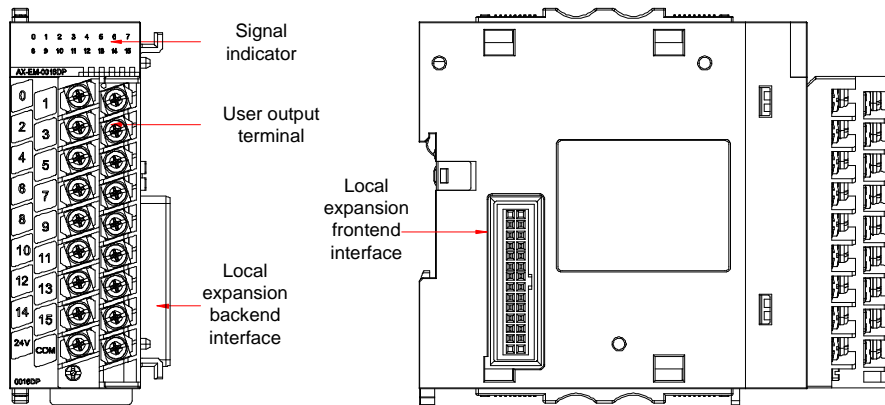

Figure 3.6 External interfaces of the digital output module

Interface	Function
Signal indicator	Each corresponds to a channel of output signal. An indicator is on when the output is valid, and it is off when the output is invalid.
User output terminal	16 outputs
Local expansion frontend interface	Connects to frontend modules, disallowing hot swapping.
Local expansion backend interface	Connects to backend modules, disallowing hot swapping.

3.4.4 AX-EM-4AD analog input module

3.4.4.1 Specifications

Table 3.15 Power supply requirement

Item	Range
Power supply voltage	Internally powered, 5VDC (-10% – +10%)
Power consumption of internal 5V	138mA (Typical value)

Table 3.16 Performance parameters

Item	Specifications
Input channel	4
Voltage input resistance	2.4MΩ
Current sampling impedance	240Ω
Voltage input range	Bipolar: ±5V, ±10V; Unipolar: +5V, +10V
Current input range	0mA–20mA, 4mA–20mA, ±20mA
Resolution	24 bits
Sampling period	1ms
Accuracy in room temperature (of 25°C)	Voltage ± 0.1%; current ± 0.1% (full measuring range)
Limit voltage	± 12V
Limit current	± 24mA
Max. common-mode voltage between channels	30VDC
Isolation method	I/O terminals insulated from the power supply; No insulation between channels
Program upgrade method	Upgrade through serial ports

3.4.4.2 Interface description

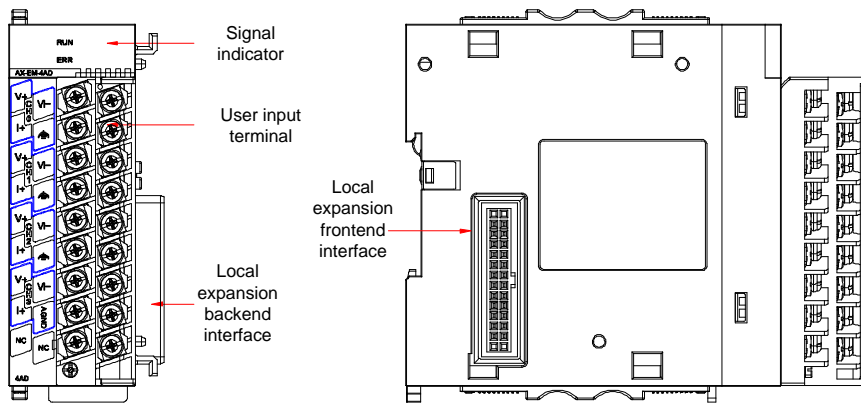

Figure 3.7 External interfaces of the analog input module

Table 3.17 External interfaces of the analog input module

Interface	Function
Signal indicator	RUN: running status indicator. It is on when the running is normal, and it is off when the running is abnormal. ERR: error status indicator. It is on when the running is abnormal, and it is off when the running is normal.
User input terminal	4 inputs
Local expansion frontend interface	Connects to frontend modules, disallowing hot swapping.
Local expansion backend interface	Connects to backend modules, disallowing hot swapping.

3.4.5 AX-EM-4DA analog output module

3.4.5.1 Specifications

Table 3.18 Power supply requirement

Item	Specifications
Power supply	24VDC (-15% – +20%)
Power consumption of internal 5V	100mA (Typical value)

Table 3.19 Performance parameters

Item	Specifications
Voltage output range	Bipolar: ±5V, ±10V; Unipolar: +5V, +10V
Current output range	4mA–20mA, 0mA– 20mA
Voltage output load	1kΩ–1MΩ
Current output load	0Ω–1kΩ
Accuracy in room temperature (of 25°C)	Voltage ± 0.1%; current ±0.1% (full measuring range)
Resolution	16 bits
Conversion time	1ms/channel
Output short circuit protection	Supported
Program upgrade method	Upgrade through serial ports
Isolation method	Output terminals insulated from the power supply; No insulation between channels

3.4.5.2 Interface description

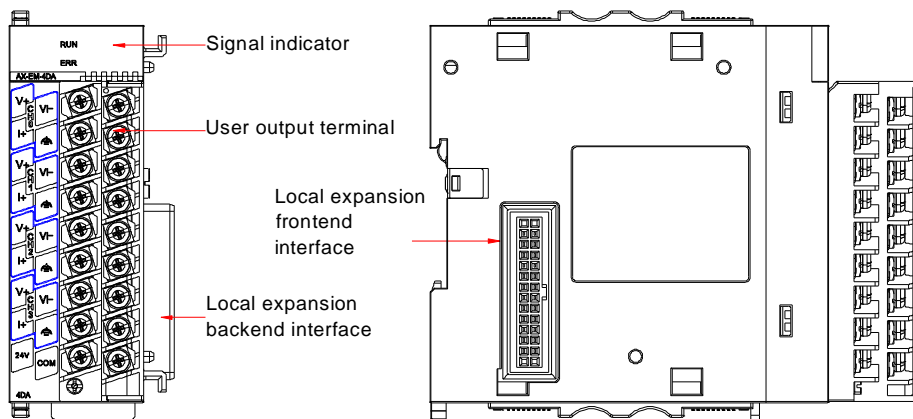

Figure 3.8 External interfaces of the analog output module

Table 3.20 External interfaces of the analog output module

Interface	Function
Signal indicator	RUN: running status indicator. It is on when the running is normal, and it is off when the running is abnormal. ERR: error status indicator. It is on when the running is abnormal,

Interface	Function
	and it is off when the running is normal.
User output terminal	4 outputs
Local expansion frontend interface	Connects to frontend modules, disallowing hot swapping.
Local expansion backend interface	Connects to backend modules, disallowing hot swapping.

3.4.6 AX-EM-4PTC temperature module

3.4.6.1 Specifications

Table 3.21 Power supply requirement

Item	Range
Power supply voltage	Internally powered, 5VDC (-10% – +10%)
Power consumption of internal 5V	150mA (Typical value)

Table 3.22 Performance parameters

Item	Specifications	
Input channel	4	
Sensor type	TCs: Types B, E, J, K, N, R, S, T RTDs: PT100, PT500, PT1000, CU100	
Display method	Celsius degree (°C), Fahrenheit degree (°F)	
Wiring method	For TCs: two-wire For RTDs: two-, three-, or four-wire	
Cold junction compensation method for TC measuring	Internal/external cold junction compensation (configurable through software)	
Resolution	24 bits	
Sensitivity	0.1°C, 0.1°F	
Sampling period	250Ms/500ms/1000ms/4 channels (configurable through software)	
Accuracy in room temperature (of 25°C)	For TCs: Full measuring range*±0.1%±1°C	For RTDs: Full measuring range * ±0.3%
Accuracy in ambient temperature (0°C–50°C)	For TCs: Full measuring range*±0.3%±1°C	For RTDs: Full measuring range * ±1%
Isolation method	I/O terminals insulated from the power supply;	No insulation between channels
Program upgrade method	Upgrade through serial ports	

3.4.6.2 Interface description

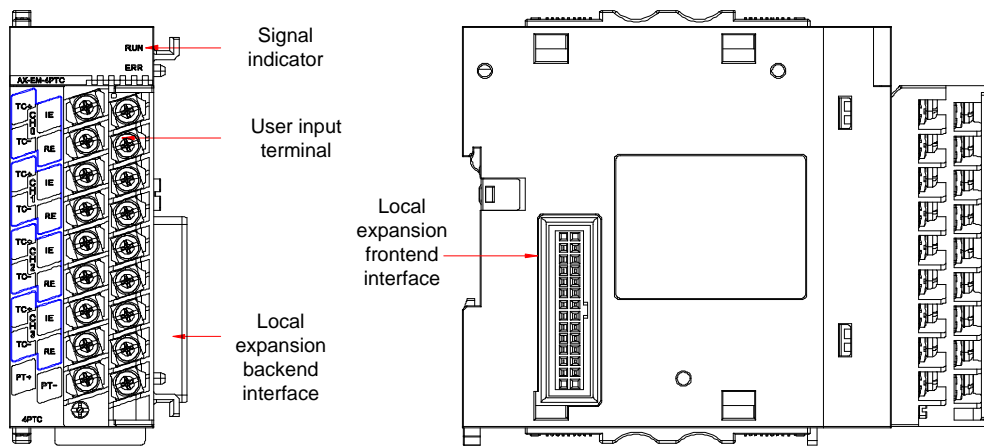

Figure 3.9 External interfaces of the temperature module

Table 3.23 External interfaces of the temperature module

Interface	Function
Signal indicator	RUN: running status indicator. It is on when the running is normal, and it is off when the running is abnormal. ERR: error status indicator. It is on when the running is abnormal, and it is off when the running is normal.
User input terminal	4 inputs
Local expansion backend interface	Connects to backend modules, disallowing hot swapping.
Local expansion frontend interface	Connects to frontend modules, disallowing hot swapping.

3.4.7 AX-EM-RCM-ET EtherCAT communication module

3.4.7.1 Specifications

Table 3.24 General specifications

Item	Specifications
Power supply specifications	24VDC (-15% – +20%)
Communication protocol	EtherCAT industrial real-time bus protocol
Max. communication rate	Ethernet 100Mbps
Transmission medium	Standard Ethernet port, configured with standard Ethernet communication cable of category 5e, with the length up to 100 meters
Node range	1–125. The internal address is automatically allocated according to the network bus connection sequence.
I/O expansion capability	16 I/O modules

Table 3.25 Performance parameters

Item	Description
Duplex mode	Full duplex
Synchronization method	Distributed clock synchronization for servo applications; input and output synchronization for I/O
Min. six-axis cam synchronization period	1ms
Topology structure	Linear
Transmission distance	Less than 100m between two nodes
Baud rate	100Mbit/s
Process data	Up to 1486 bytes contained in a single Ethernet frame
Synchronous jitter between two slave nodes	Within 1μs
Refresh time	The refresh time of 1000 digital inputs and outputs is about 30μs, and that of 32 servo applications is about 100μs.
Configuration method	Manually upload configuration files.

3.4.7.2 Interface description

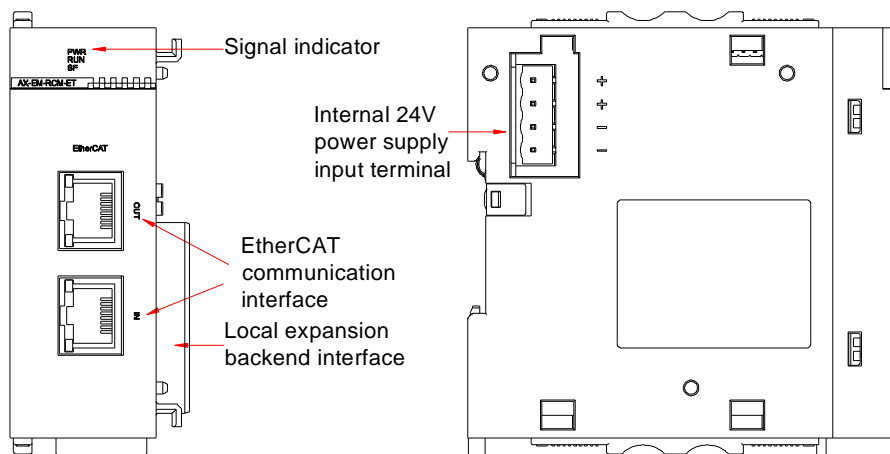

Figure 3.10 External interfaces of the EtherCAT communication module

Table 3.26 External interfaces of the EtherCAT communication module

Interface	Function			
Signal indicator	POWER	Power supply indicator	Green	It is on when the power supply is switched on.
	RUN	Run indicator	Green	It is on when the module is running properly.
	SF	Expansion bus fault indicator	Green	It is on when the

Interface	Function		
			expansion bus has a fault.
EtherCAT communication interface	IN: EtherCAT input port, used for communication with the CPU module.		
	OUT: EtherCAT output port, used for connection to backend EtherCAT slave nodes.		
Local expansion backend interface	Connects to backend modules, disallowing hot swapping.		
Input terminal of internal 24V power	Connects to the power supply module.		

4 Product installation

4.1 Installation environment requirements

4.1.1 Installation space

For the ease of replacement and heat dissipation, keep sufficient clearances between the module upper/lower parts and cabinet and between components. See the following figure.

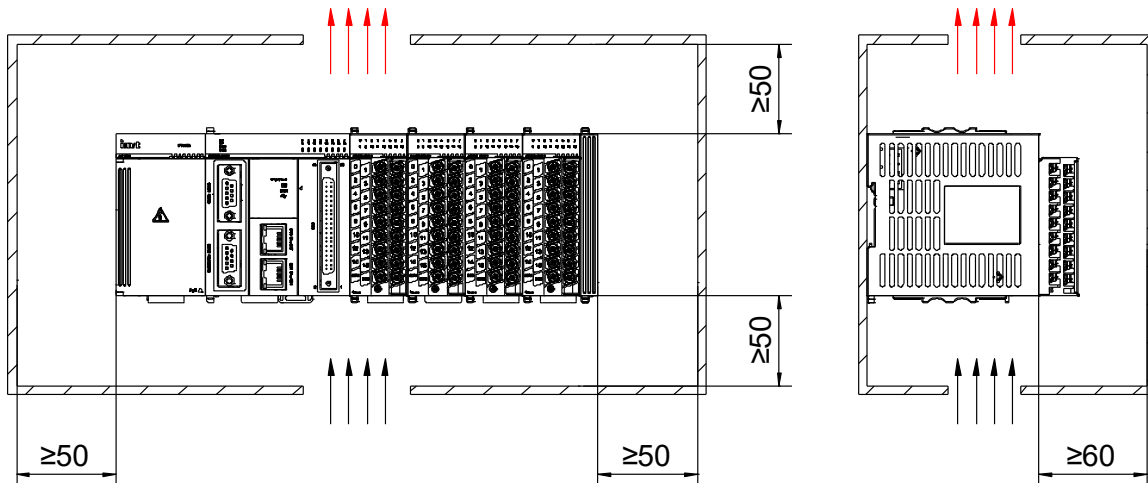

Figure 4.1 Requirements on installation space (unit: mm)

4.1.2 Check before installation

- Make sure all product modules have been powered off before installation.
- Check the planned overall size and ensure that there is enough space to accommodate the product modules. The product must be installed in a cabinet with each clearance to the surrounding greater than 50mm so that the product hardware has good heat dissipation.
- Check the installation environment and ensure that the environment meets the working conditions of all the components of the product, which include temperature, humidity, dust and corrosion protection requirements. Do not install the product or its modules in an environment with any of the following conditions:
 - Ambient temperature is out of the range of -5°C – $+55^{\circ}\text{C}$.
 - Relative humidity is out of the range of 5%–95%.
 - Temperature changes sharply, and condensation may occur.
 - There is explosive or flammable gas.
 - There is dust, conductive powder such as iron powder, oil mist, salt, and organic solvents.
 - With direct sunlight.
 - Strong electric or magnetic fields occur.
 - With factors that will cause the product or modules to directly vibrate or suffer conductive shocks.

4.1.3 Installation precautions

- If required, use the installation tools that meet the requirements, such as screws and gaskets.
- Prevent screws, cables and other conductive parts from falling into the internal of the product. Otherwise, short circuit may occur, or heat dissipation may be degraded.
- Do not use fasteners with excessive torque. Otherwise, terminals may be damaged.

4.1.4 Check after installation

- Ensure that the terminal of the connected communication cable is firmly fastened.
- Ensure that the rail that hosts the module is reliably fixed.
- Ensure that the strong-electricity cables are separately routed from the weak-electricity cables, and the cables are routed neatly in the cabinet.
- Remove the sticker attached to the heat dissipation hole of the module to make the heat dissipation smooth.

4.2 Installation method

4.2.1 Module installation procedure

Perform installation as follows:

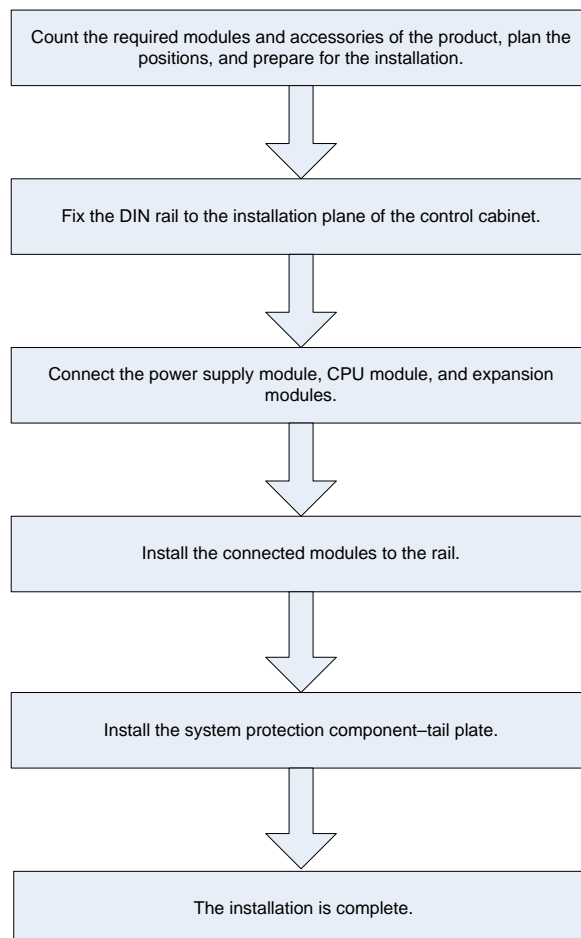



4.2.2 Fixing the DIN rail to the installation plane of the control cabinet

You can prepare the installation rail by yourself. The applicable DIN rail models are listed in the following table.

Table 4.1 DIN rail models and specifications

Model	Length x Height (unit: mm)	Fastening screw
TH35-7.5Fe	35x7.5	M4
TH35-7	35x7.5	M4
TH35-15Fe	35x15	M4

To ensure the strength of the DIN rail, install the DIN rail installation bolts (provided by yourself) at the places within 30mm from both ends of the DIN rail, and tighten the bolts at intervals within 200mm.

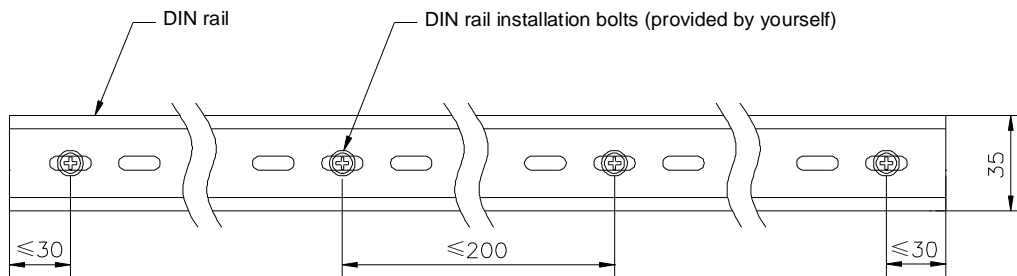
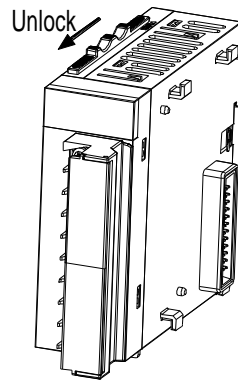

Figure 4.2 DIN rail installation (unit: mm)

4.2.3 Connecting the power supply module, CPU module, and expansion modules

The modules are connected by using the module-provided connection interfaces and snap-fits. The following describes how to connect the CPU module to an expansion module. The connection between other modules is similar.

Step 1 Slide the snap-fit on the analog input module in the direction shown in following figure.



Step 2 Align with the connector on the CPU module for interlocking.

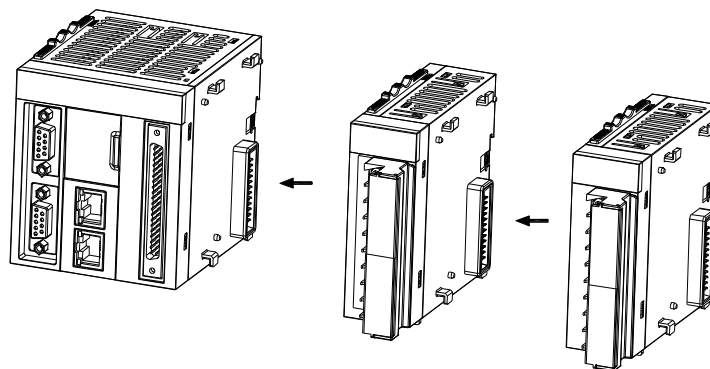

Step 3 Slide the snap-fit on analog input module in the direction shown in the following figure to connect and lock the two modules.

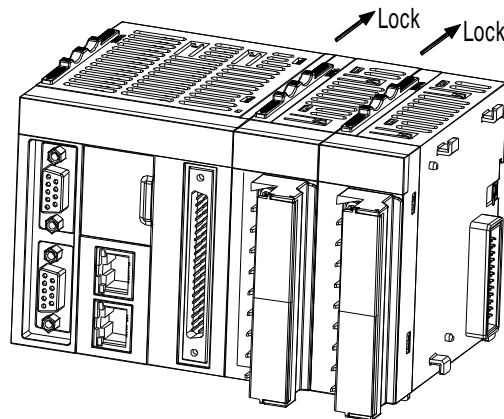

4.2.4 Installing the connected modules to the DIN rail

As for standard DIN rail installation, hook the respective module into the standard installation rail until the snap-fit clicks into place.

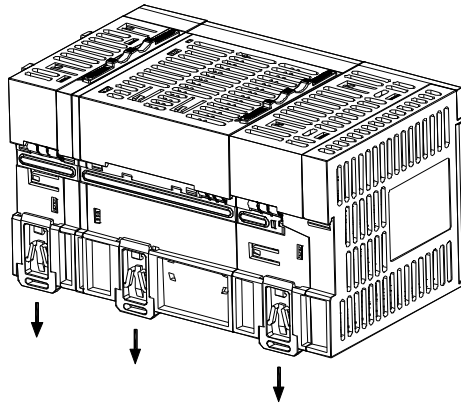

4.2.5 Installing the system protection component—protective tail plate

Install a protective tail plate to prevent the connection port of the last module from being directly exposed.

4.3 Disassembling and assembling a terminal block

4.3.1 Disassembly procedure

- Step 1 Open the terminal cover and loosen the terminal block mounting bolts.
- Step 2 Remove the terminal block, using the terminal block fixing hole as a fulcrum.

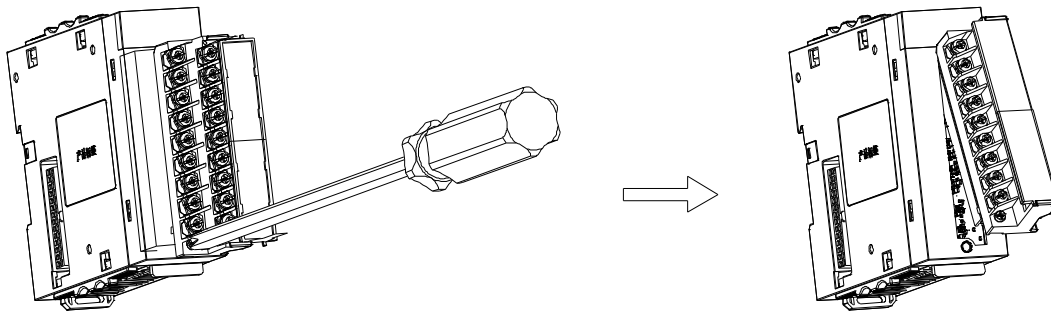

Figure 4.3 Terminal block disassembly

4.3.2 Assembly procedure

- Step 1 Insert the protruding part of the upper part of the terminal block into the terminal block fixing hole of the module, using the terminal block fixing hole as a fulcrum.
- Step 2 Open the terminal cover and fasten the terminal block mounting bolts.

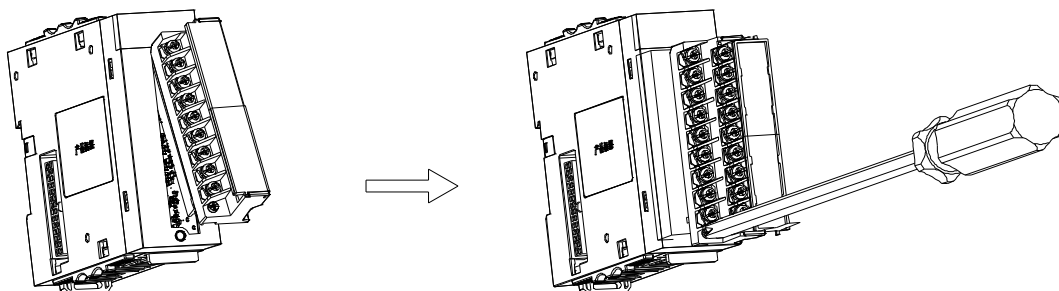

Figure 4.4 Terminal block assembly

4.4 Assembling and disassembling an SD storage card

4.4.1 Assembling an SD storage card

An SD storage card adopts a push-push structure. After opening the small flip cover of the CPU module, push the card into the SD card holder in the direction shown in the following figure.

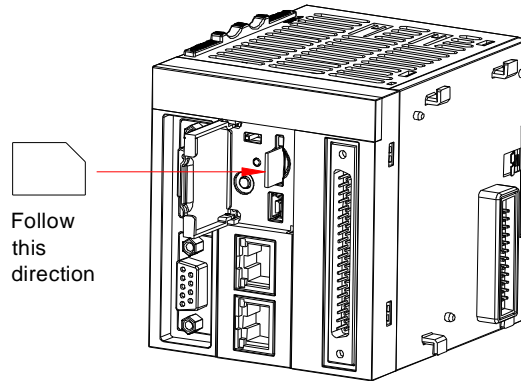

Figure 4.5 SD storage card assembly

Ensure that the SD storage card is pushed into place. Otherwise, malfunction can be caused due to poor contact.

4.4.2 Disassembling an SD storage card

Press the SD storage card once, and take away the SD storage card after the SD card is ejected.

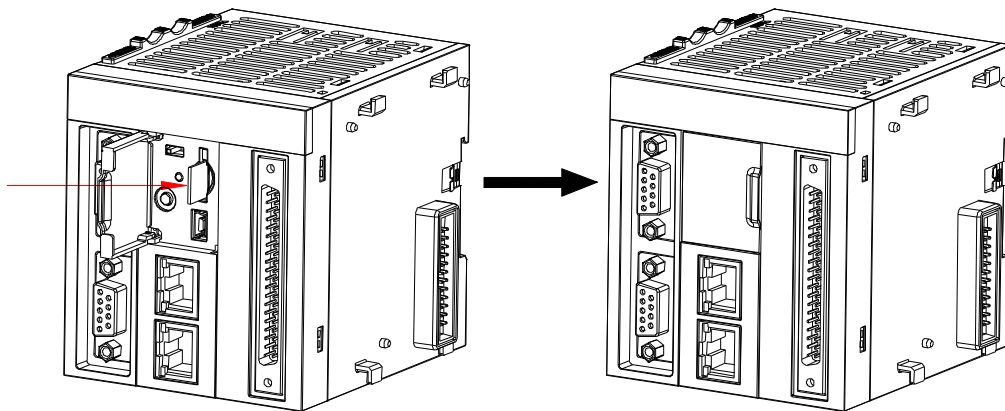
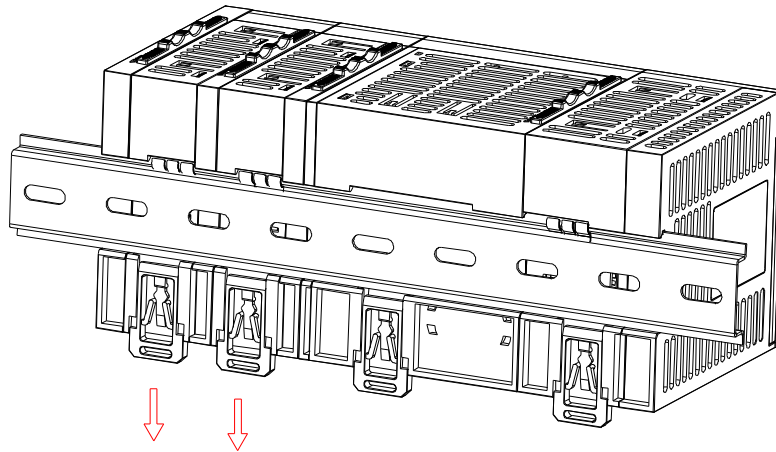

Figure 4.6 SD storage card disassembly

4.5 Replacing a module

If you need to replace a module that has been installed on the DIN rail, you must first remove the corresponding cables of the module, or remove the terminal block cables. After removing the cables, do as follows:

Step 1 Pull out the DIN rail mounting hooks on the back of the module to be replaced and the rightward module in the downward direction.



Pull the mounting hooks in the arrow direction.

The pull-out is correct only when you hear a click sound. In addition, if you cannot reach the DIN rail mounting hook with your fingers, use a tool such as a screwdriver.

Step 2 Slide the snap-fits on the module to be replaced and the rightward module to unlock. See the following figure.

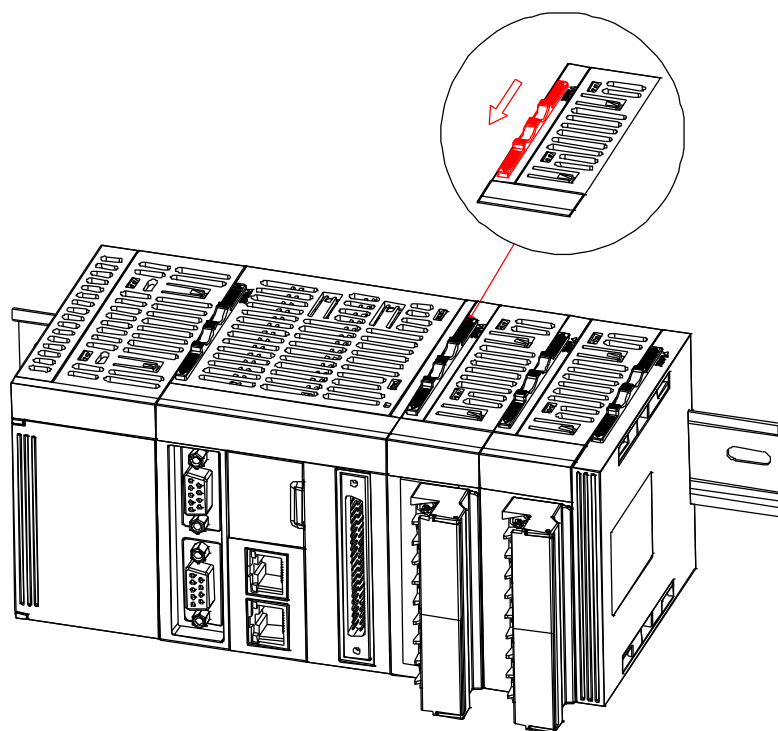

Slide the snap-fit on a module in the upward direction for unlocking.

Step 3 Slide the module to be displaced.

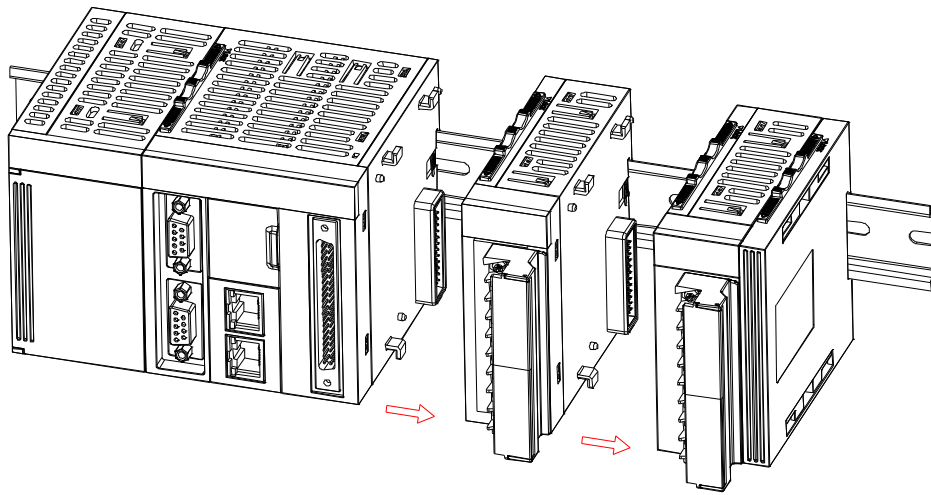

Slide the module in the arrow direction.

Step 4 Replace the module.

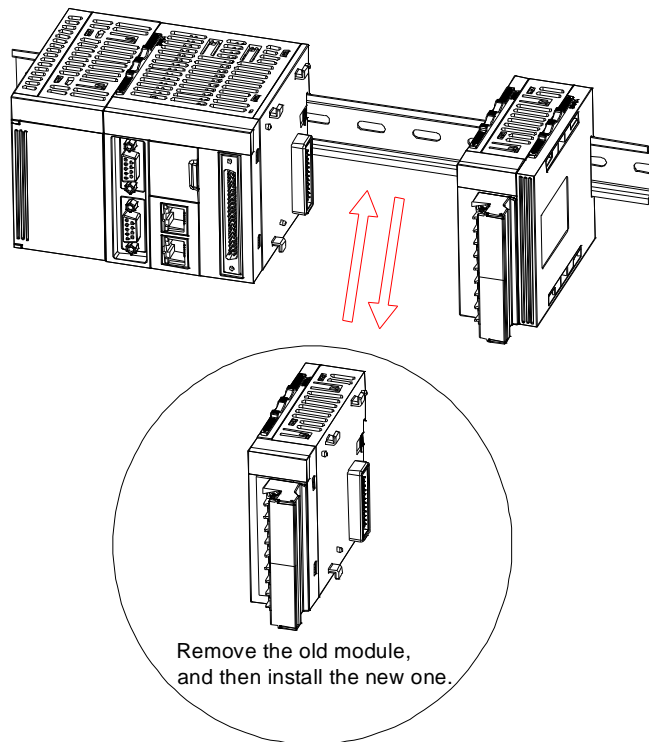

Replace the module with another.

Step 5 Slide the involved modules and connection them.

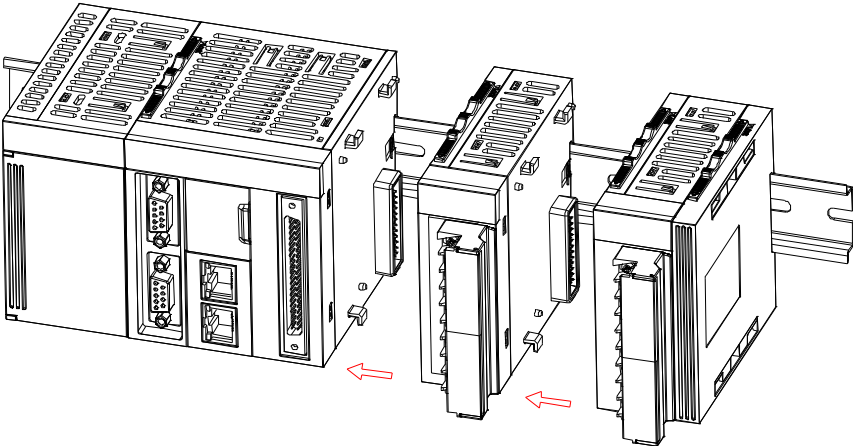

Slide the modules in the arrow direction.

Step 6 Lock the modules.

5 Wiring



5.1 Wiring suggestions

5.1.1 Wiring precautions

- Before installing or wiring, turn off all external power supplies. Failure to turn off all power supplies may cause electric shock or product damage.
- After completing the installation or wiring, ensure the module terminal cover has been installed properly before turning on the power or operating the module. Otherwise, electric shock or maloperation can result.
- Before wiring the programmable controller, check the rated voltage and terminal configuration according to product specifications, ensuring safe wiring. The connection to a power supply that does not match the ratings or incorrect product wiring may cause serious accidents such as fire and product damage.
- Tighten screws using required torque. If screws are loose, short circuit, fire, or maloperation may result. If terminal screws are too tightened, screw or module damage, falling, short circuit, or faults may result.
- Ensure that there are no foreign objects such as metal scraps or wiring residues in each module. The foreign objects may cause short circuit, fire, or maloperation.

5.1.2 Grounding

Grounding requirements of power cables

- Use correct, independent wiring methods.
- Connect the ground cable with the cross-sectional area $\geq 2\text{mm}^2$ and length $\leq 30\text{cm}$ to the ground terminals  and  of the power supply module.
- The ground point is close to the programmable controller, and the ground cable is firmly connected.

Grounding requirements of shield cables

Use shield cables for analog I/O, RS485, and EtherCAT cables and other cables that transmit sensitive signals. Ground as close as possible to the modules. For the shield part exposed after some of the shield cable is stripped, ground the part and the conductive backplane with an area as large as possible to ensure good contact.

5.1.3 Installing an insulation transformer

If there is high-power equipment at the application site that causes greater surge interference to the power grid, you can install an insulation transformer on the AC circuit that independently supplies power to the power supply module. The measure of installing an insulation transformer can realize the electrical isolation between the power supply module and the power frequency of the high-power equipment that generates surge interference, so as to avoid the possibility of surge interference causing the programmable controller to malfunction.

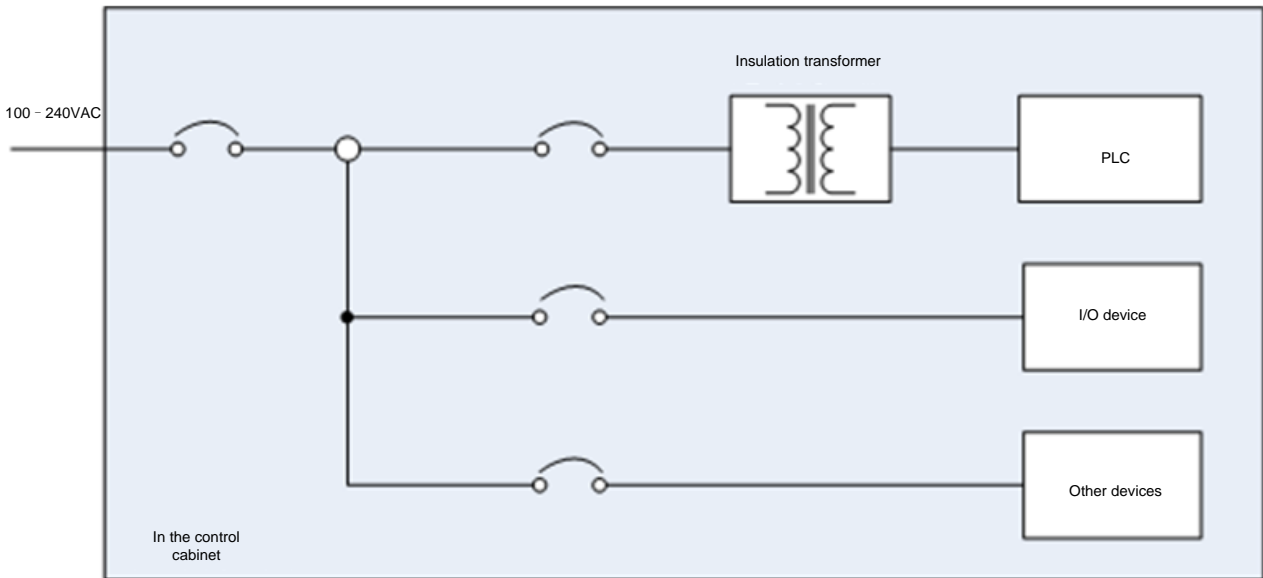

Figure 5.1 Insulation transformer working diagram

5.2 Wiring the power supply module

5.2.1 Power supply module terminals

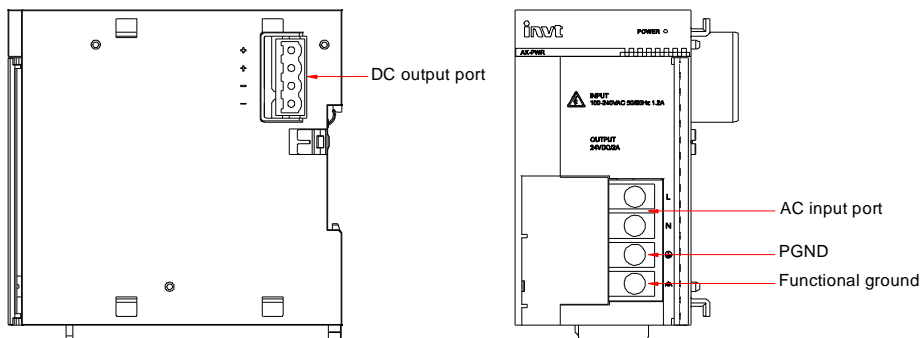

Figure 5.2 External interfaces of the power supply module

Table 5.1 External interfaces of the power supply module

Interface	Symbol	Function
Input port		
AC input	L, N	100VAC–240VAC input
Protection ground	⊕	Connects to AC input power ground wire.
Function ground	⊕	Connects to the system housing.
Output port		
+24V	+	+24V DC output
GND	-	DC output ground

5.2.2 Wiring precautions



- The AC power must have been turned off before wiring. Otherwise, electric shock, personal injury, or module

damage can result.

- Do not bind the 110V/220V AC power cable together with the 24V power cable, I/O signal cable, or communication cable, or route the 110V/220V AC power cable with the latter adjacently. The distance between such cables must be at least 100mm.
- For AC 110V/220V and DC 24V cables, use single- or multi-core thick wires (16-22AWG), and use kgf.cm as the power terminal screw torque.

5.2.3 Grounding

Step 1 Connect the two terminals L and N of the AC power supply (100–240VAC, 50/60Hz) to the terminals L and N of the power supply module, and connect the ground wire of the power supply to the protective ground terminal  of the module.

Step 2 If the application site does not have a power ground wire, make short circuit between the protective ground terminal  and function ground terminal  of the power supply module, and then connect the ground wire to the cabinet housing, as shown in the following figure.

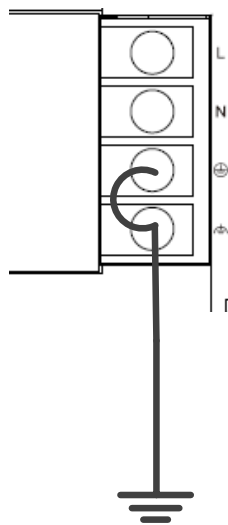

Step 3 The function ground terminal  of the power supply module is connected to the cabinet housing to function as the reference ground. Comply with the following rules for grounding:

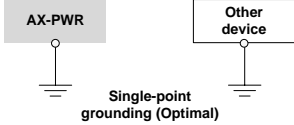
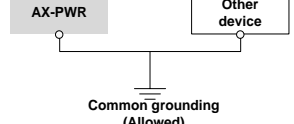
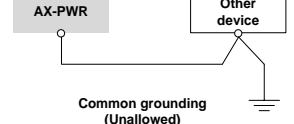
 <p>Single-point grounding (Optimal)</p>	<ul style="list-style-type: none"> The diameter of the ground wiring cannot be less than the wire diameter of the power terminals L and N. Perform single-point grounding when multiple types of equipment are used at the same time.
 <p>Common grounding (Allowed)</p>	<ul style="list-style-type: none"> If single-point grounding cannot be performed, use the common ground method.
 <p>Common grounding (Unallowed)</p>	<ul style="list-style-type: none"> During grounding, the grounding method shown in the figure cannot be used.

5.2.4 Installing a power filter

If AX series modules are used in a site with strong interference sources (such as VFDs), it is recommended to add additional noise filters to suppress interference noise.

Install the filter as close to the AX-PWR power supply module as possible, and connect it to the conductive backplane using screws. To ensure good grounding, apply coating protection to the screw area. In principle, route the cables leading to the filter separately from the cables coming out of the filter to prevent the cable noise before filtering from being coupled to the filtered cable.

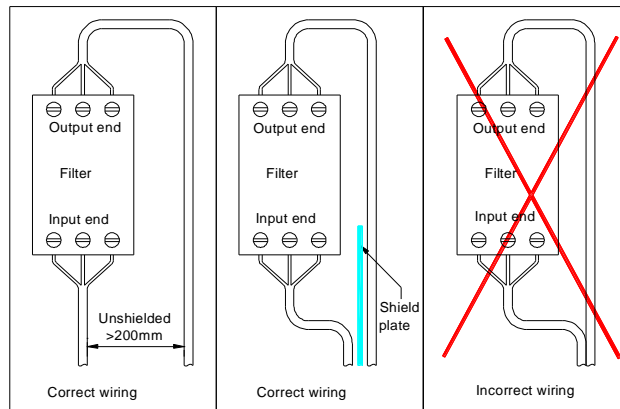

Figure 5.3 Power filter installation diagram

5.3 Wiring AX7□-C-1608□ CPU module

5.3.1 High-speed I/O wiring

5.3.1.1 For AX7□-C-1608P

The high speed I/O port of AX7□-C-1608P CPU module has 16 high-speed inputs and 8 high-speed outputs. The following figure shows the terminal distribution.

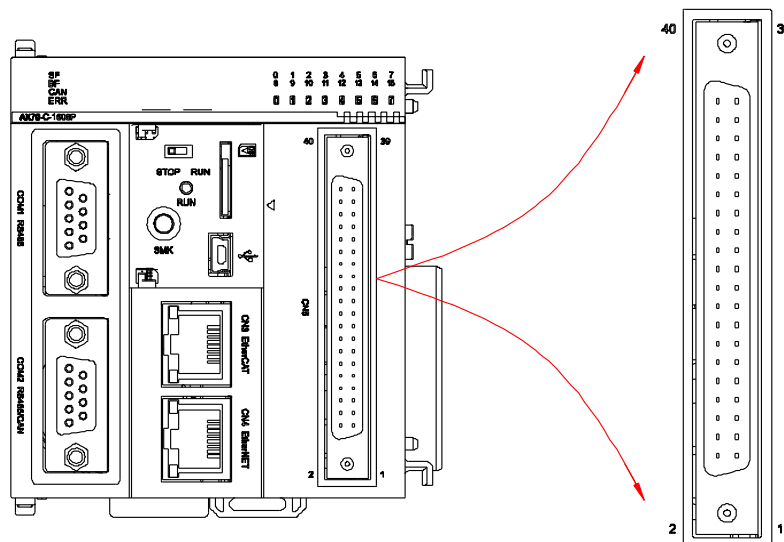

Figure 5.4 High-speed I/O wiring of AX7□-C-1608P

Note:

- All 16 input channels of the CPU module allow high-speed input, but the first 6 channels support 24V single-end or differential input, and the last 10 channels support 24V single-end input.

- The connection from each I/O point to the internal circuit is isolated by using an optocoupler.
- The total length of high-speed I/O port connection cable cannot exceed 3 meters.
- Do not bend the cables when fastening the cables.
- During cable routing, separate the connection cables from high-power cables that cause strong interference but not bind the connection cables with the latter together. In addition, avoid long-distance parallel routing.

The external wiring of high-speed I/O is described in the following figure.

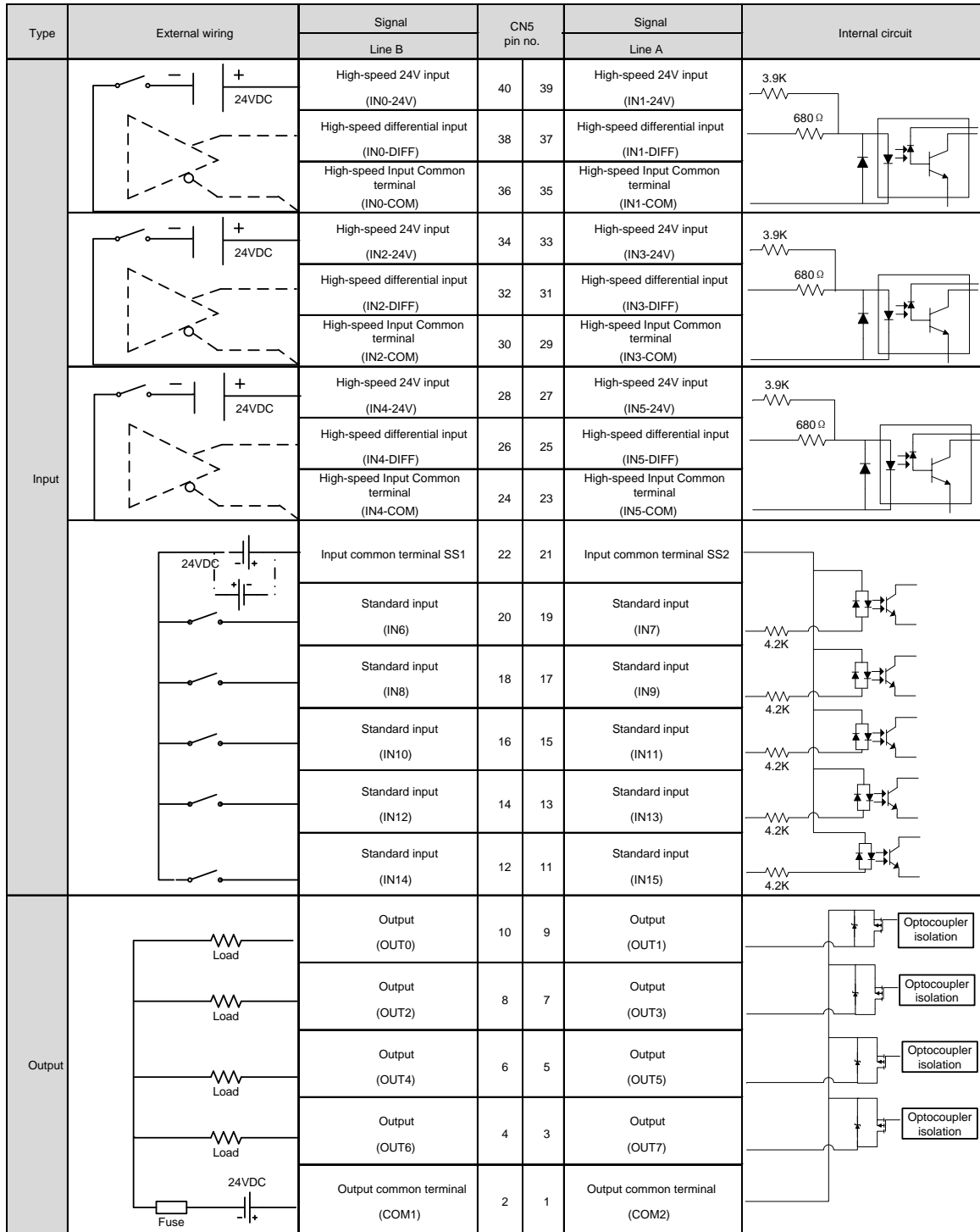

Figure 5.5 External wiring of high-speed I/O

AX-HIO-40 terminal block can be used for transfer wiring. See the following figure.

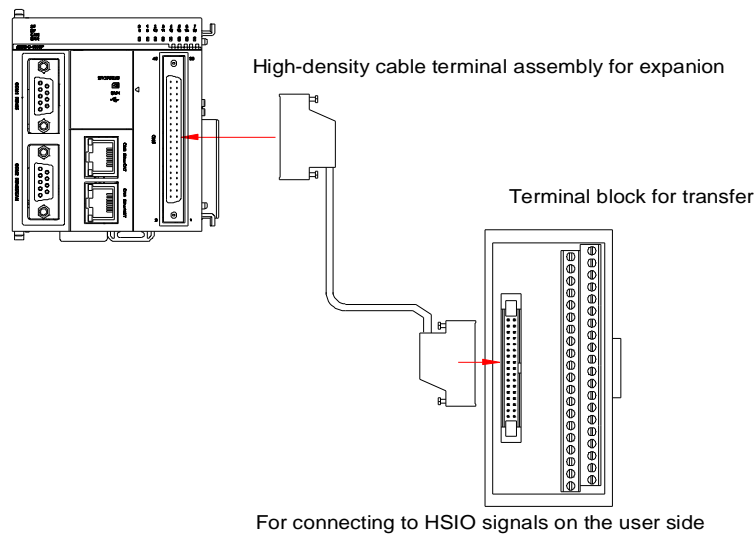

Figure 5.6 Transfer wiring

Note: The CN5 pin numbers respectively correspond to the terminal numbers of the high-density expansion transfer terminal block.

5.3.1.2 For AX7□-C-1608N

The high speed I/O port of AX7□-C-1608N CPU module has 16 high-speed inputs and 8 high-speed outputs. The following figure shows the terminal distribution.

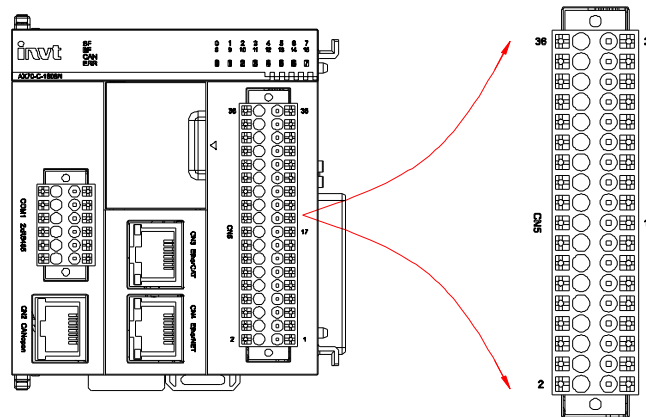

Figure 5.7 High-speed I/O wiring of AX7□-C-1608N

Note:

- All 16 input channels of the CPU module allow high-speed input, but the first 4 channels support differential input, and the last 12 channels support 24V single-end input.
- The connection from each I/O point to the internal circuit has been processed for isolation.
- The total length of high-speed I/O port connection cable cannot exceed 3 meters.
- Do not bend the cables when fastening the cables.
- During cable routing, separate the connection cables from high-power cables that cause strong interference but not bind the connection cables with the latter together. In addition, avoid long-distance parallel routing.

The external wiring of high-speed I/O is described in the following figure.

Type	External wiring	Signal	CN5 pin no.		Signal	Internal circuit
		Line B			Line A	
Differential input		High-speed differential input (A0+)	36	35	High-speed differential input (B0+)	
		High-speed differential input (A0-)	34	33	High-speed differential input (B0-)	
	High-speed differential input (A1+)	32	31	High-speed differential input (B1+)		
	High-speed differential input (A1-)	30	29	High-speed differential input (B1-)		
Single-end input		Standard input (X4)	28	27	Standard input (X5)	
		Standard input (X6)	26	25	Standard input (X7)	
		Standard input (X8)	24	23	Standard input (X9)	
		Standard input (X10)	22	21	Standard input (X11)	
		Standard input (X12)	20	19	Standard input (X13)	
		Standard input (X14)	18	17	Standard input (X15)	
		Input common terminal (SS)	16	15	Input common terminal (SS)	
		Shielded ground PE	14	13	Shielded ground PE	
Output		Output common terminal (COM)	12	11	Output common terminal (COM)	
		Output (Y0)	10	9	Output (Y1)	
		Output (Y2)	8	7	Output (Y3)	
		Output (Y4)	6	5	Output (Y5)	
		Output (Y6)	4	3	Output (Y7)	
		Shielded ground PE	2	1	Shielded ground PE	

5.3.2 Communication interface wiring

As shown in the following figure, AX7□-C-1608P CPU module mainly provides two RS485 interfaces, one EtherCAT interface, one Ethernet interface, one USB interface, one CANopen interface, and one MicroSD interface, implementing the connection to different equipment according to requirements.

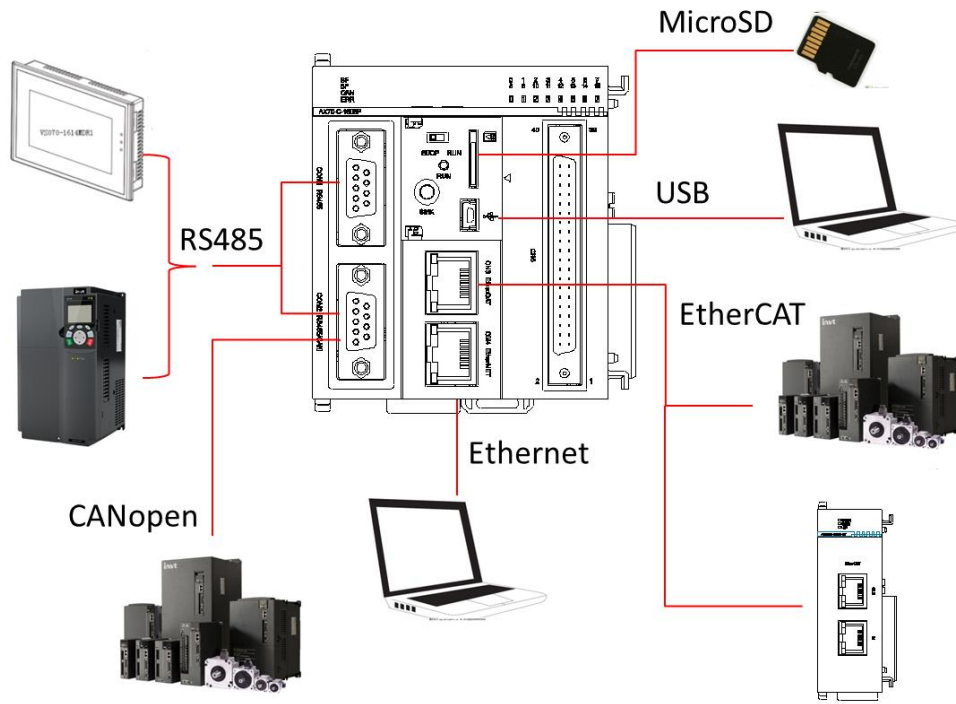

Connecting through the RS485 bus

AX7□-C-1608P CPU module provides two DB9 ports, in which COM1 is the RS485 communication port and COM2 is the RS485 and CAN communication port. The interfaces and pins are described in the following.

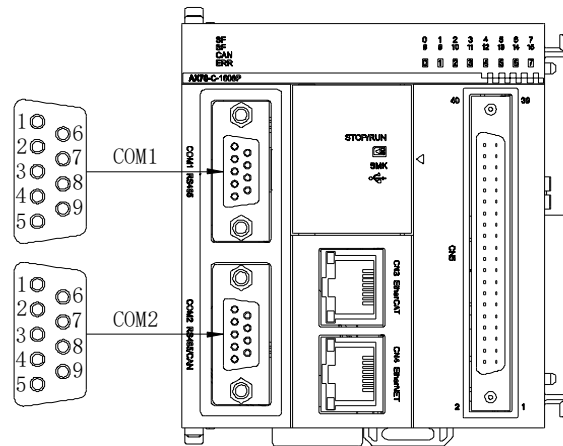
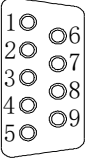

Figure 5.8 DB9 interface distribution

Port	Distribution	Pin	Definition	Function
COM1 (RS485)		1	/	/
		2	/	/
		3	/	/
		4	RS485A	RS485 differential signal +
		5	RS485B	RS485 differential signal -
		6	/	/
		7	/	/
		8	/	/

Port	Distribution	Pin	Definition	Function
COM2 (RS485/CAN)		9	GND_RS485	RS485 communication ground
		1	/	/
		2	CAN_L	CAN differential signal -
		3	/	/
		4	RS485A	RS485 differential signal +
		5	RS485B	RS485 differential signal -
		6	GND_CAN	CAN communication ground
		7	CAN_H	CAN differential signal +
		8	/	/
9	GND_RS485	RS485 communication ground		

For an AX7□-C-1608N CPU module, COM1 is a two-channel RS485 communication port, using 12-pin in-line terminal for data transmission, while CN2 is a CAN communication port, using an RJ45 connector for data transmission. The interfaces and pins are described in the following.

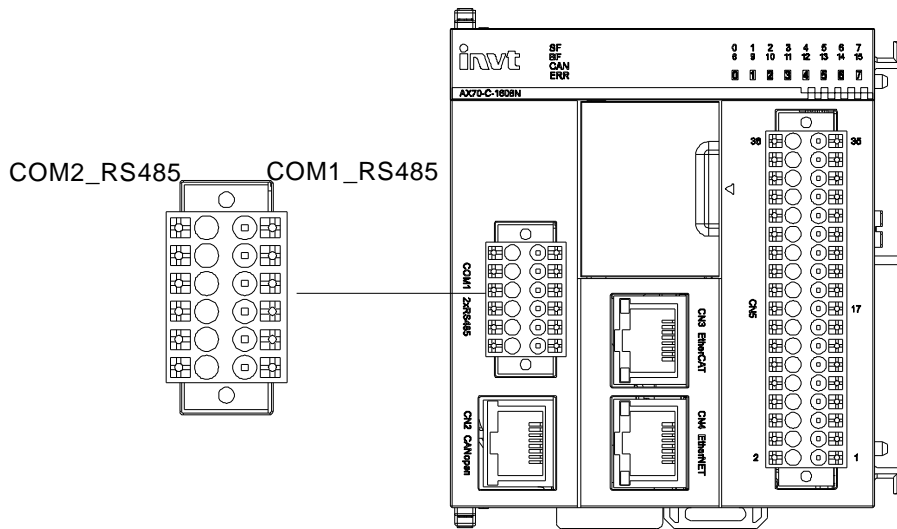
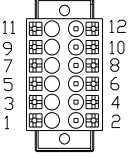
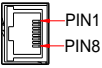

Figure 5.9 COM1/CN2 interface distribution

COM1 in-line terminal functions				
Definition		Function		Pin
	COM1_RS485	A	RS485 differential signal +	12
		B	RS485 differential signal -	10
		GND	RS485_1 chip power ground	8
		PE	Shielded ground	6
	COM2_RS485	A	RS485 differential signal +	11
		B	RS485 differential signal -	9
		GND	RS485_2 chip power ground	7
		PE	Shielded ground	5
Note: Pins 1–4 are not used.				
CN2 port function				
Definition		Function		Pin
	CANopen	GND	CAN power ground	1
		CAN_L	CAN differential signal -	7
		CAN_H	CAN differential signal +	8
Note: Pins 2–6 are not used.				

The following figure shows the RS485 bus connection topology (taking AX70-C-1608P for example), which is similar to the topology of other CPU modules. It is recommended that the shielded twisted pair be used as the RS485 bus, each end of which connects a 120Ω terminal resistor to prevent signal reflection. 485A and 485B use twisted pair connection. For all nodes, the reference grounds of the 485 signal are connected together; 31 nodes can be connected at most, and the distance from the bus to each node must be less than 3 meters.

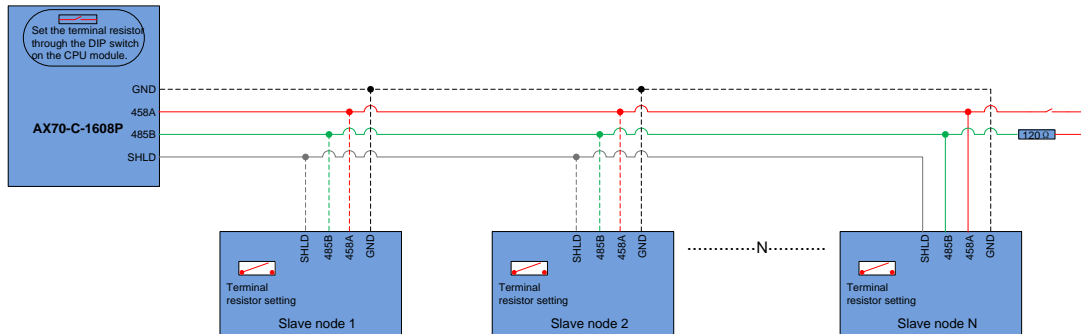

Figure 5.10 RS485 bus connection topology structure

◇ Multi-node connection method

When there are many nodes, the 485 bus must use the chrysanthemum connection method. If branch line connection is required, make the branch line length from the bus to each node as short as possible, and it is recommended that the branch line length not exceed 3 meters. The start connection method cannot be used.

◇ Terminal connection method

- For a node with a CGND (communication ground, RS485_GND) wiring point at the port:

Check the cables for connecting the RS485 bus to the terminals 485A, 485B, and CGND. Ensure that signal cables and terminals are connected correctly. If you use shielded cables, the shield layers must also and only be connected to the terminal CGND.

Due to the attenuation effect of cables, use AGW26 or thicker cables when the connection length greater than 3 meters. At any time, twisted pairs are recommended for 485A and 485B connection cables.

Wiring cable recommendation 1: When a multi-core twisted-pair cable is used, use one twisted pair as the connection wire of 485A and 485B, and twist the others together as the connection wire of CGND.

Wiring cable recommendation 2: When a shielded twisted-pair cable is used, use the twisted pair as the connection wire of 485A and 485B, and use the shield layer as the connection wire of CGND.

For scenarios where a shielded cable is used as a connection cable, the shield layer can only be connected to CGND but not the onsite ground.

- For a node without a CGND connection point, you cannot simply connect CGND or the shield layer directly to the PE of the node, but do as follows:
 - (1) Search other ports of this node for a reference ground shared with the RS485 circuit. If the reference ground is found, connect the CGND cable (shield layer) of the bus to this pin directly.
 - (2) Find the reference ground of the 485 circuit on the node board, and lead out to CGND or the shield layer.
 - (3) If the reference ground of the 485 circuit cannot be found or the CGND cable or the shield layer is suspended, use additional ground wires to connect the PE of this node to the PE of other nodes.

Connecting through the CANopen bus

Networking

The CAN bus connection topology structure is shown in the following figure. The CAN bus supports 63 slave nodes. It is recommended that the shielded twisted pair be used for connection. Each end of the CAN bus connects to a 120Ω terminal resistor to prevent signal reflection. In most cases, the shield layer uses single-point grounding.

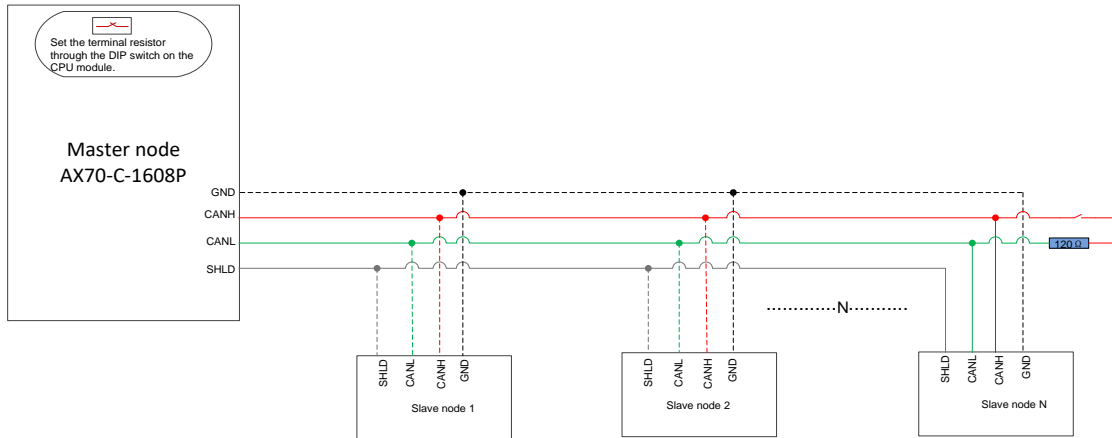

Figure 5.11 CAN bus connection

Wiring

For an AX7□-C-1608P CPU module, the same terminal is used for both CANopen communication and RS485 communication, both of which use a DB9 connector for data transmission. The pins in the DB9 connector have been described earlier. The cables in INVT AX series options are recommended. If you make the communication cables by yourself, make the cables according to the pin description and ensure the manufacturing process and technical parameters meet communication requirements.

Option	Model	Specifications
RS485/CAN communication cable	AX-L2-20	RS485/CAN communication cable (DB9 male & terminal), two meters
RS485/CAN communication cable	AX-L2-30	RS485/CAN communication cable (DB9 male & terminal), three meters
RS485/CAN communication cable	AX-L2-50	RS485/CAN communication cable (DB9 male & terminal), five meters

For an AX7□-C-1608N CPU module, an in-line RJ45 connector is used for CANopen communication. If you make the communication cables by yourself, make the cables according to the pin description and ensure the manufacturing process and technical parameters meet communication requirements.

Note:

- To enhance cable anti-interference capability, you are recommended to use aluminum foil shielding and aluminum-magnesium braid shielding techniques when making the cables.
- Use the twisted-pair winding technique for differential cables.

5.3.2.3 Connecting through the EtherCAT bus

The CPU module communicates with remote modules through the industrial Ethernet EtherCAT protocol. The CPU module as the master node supports the expansion of up to 125 EtherCAT slave nodes. They use network cables as the transmission medium.

EtherCAT bus specifications

Item	Description
Communication protocol	EtherCAT

Item	Description
Supported service	COE (PDO/SDO)
Min. synchronization period	1ms/4 axis (typical value)
Synchronization method	DC
Physical layer	100BASE-TX
Duplex mode	Full duplex
Topology structure	Serial connection
Transmission medium	Network cable (see the section "Cable selection")
Transmission distance	Less than 100m between two nodes
Number of slave nodes	Up to 125
EtherCAT frame length	44 bytes–1498 bytes
Process data	Up to 1486 bytes contained in a single frame

Cable selection

The CPU module can implement EtherCAT bus communication through the CN4 port. The cables in INVT AX series options are recommended.

Option	Model	Specifications
Shielded cable for communication	AX-L3-20	Shielded cable for communication, L=2m; AX-L3-20; RoHS
Shielded cable for communication	AX-L3-50	Shielded cable for communication, L=5m; AX-L3-50; RoHS

EtherCAT communication cable requirements

If you make the communication cables by yourself, ensure the cables meet the following requirements:

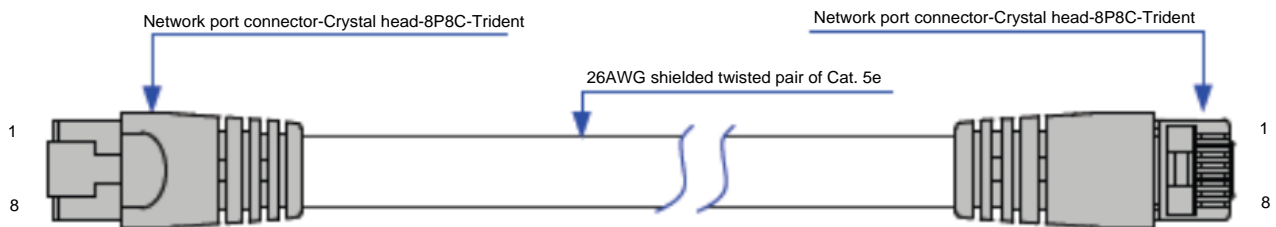

Figure 5.12 Self-made network cable requirements

Note:

- The communication cables you use must pass the conductivity test 100%, without short circuit, opened circuit, dislocation or poor contact.
- To ensure communication quality, the EtherCAT communication cable length cannot exceed 100 meters.
- You are recommend to make the communication cables by using the shielded twisted pair cables of category 5e, compliant with EIA/TIA568A, EN50173, ISO/IEC11801, EIA/TIA bulletin TSB, and EIA/TIA SB40-A&TSB36.

5.3.2.4 Connecting through the Ethernet

Networking

The Ethernet port of the CPU module is CN3, which can connect to another device such as a computer or HMI device by using a network cable in the point-to-point mode.

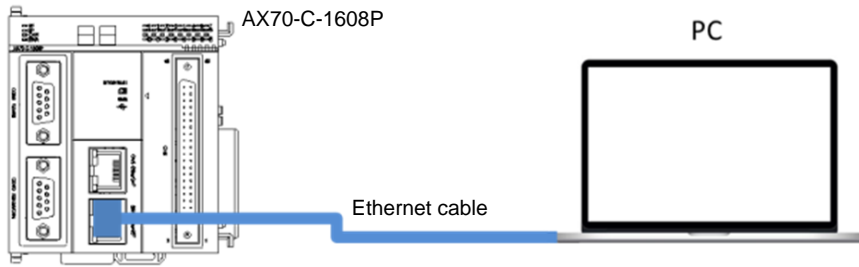

Figure 5.13 Ethernet connection

You can also connect the Ethernet port to a hub or switch by using a network cable, implementing multi-point connection.

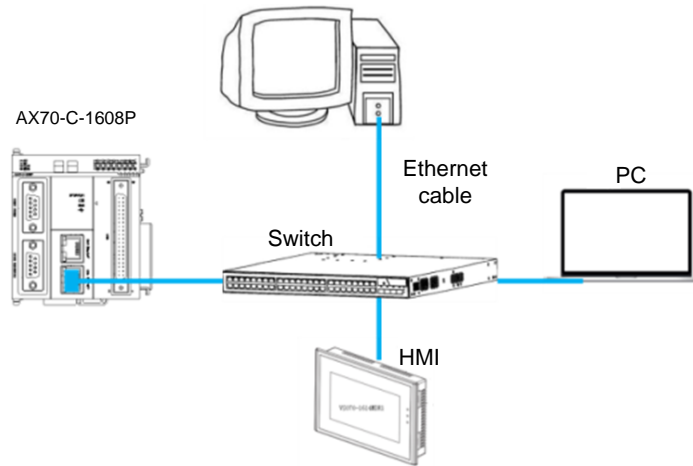

Figure 5.14 Ethernet networking

Cable selection

To improve communication reliability, use shielded twisted-pair cables of category 5 or higher as Ethernet cables. The cables in INVT AX series options are recommended.

Option	Model	Specifications
Shielded cable for communication	AX-L3-20	Shielded cable for communication, L=2m; AX-L3-20; RoHS
Shielded cable for communication	AX-L3-50	Shielded cable for communication, L=5m; AX-L3-50; RoHS

5.4 Wiring expansion modules

5.4.1 AX-EM-1600D digital input module

The wiring terminals of AX-EM-1600D digital input module are shown in the following figure. This module supports 16 digital inputs of the source or sink type, and uses internal 5V power supply without the connection to an external power supply.



The terminal wiring is as follows:

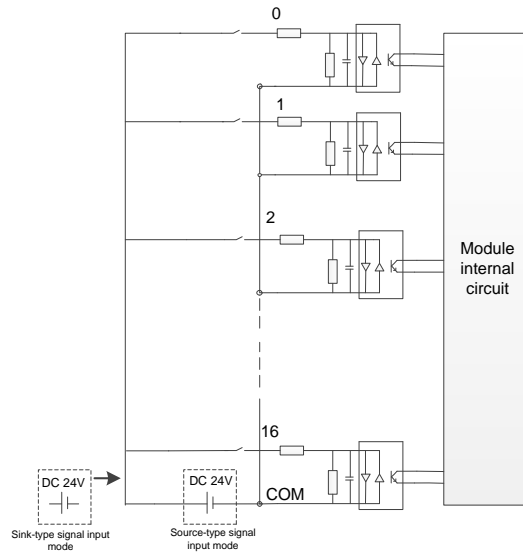

Figure 5.15 AX-EM-1600D terminal wiring

Note:

- The module needs to be installed on a properly-grounded metal bracket, and the metal dome at the module bottom must be in good contact with the bracket.
- Do not bind the digital input cable together with the AC cable, main circuit cable, or high-voltage cable. Otherwise, the binding can increase noise, surge, and induction impact. When using shielded cables, use single-point grounding for the shield layer.

5.4.2 AX-EM-0016DP digital output module

The wiring terminals of AX-EM-0016DP digital output module are shown in the following figure. This module supports 16 digital outputs of the source type, and uses an external 24VDC power supply.

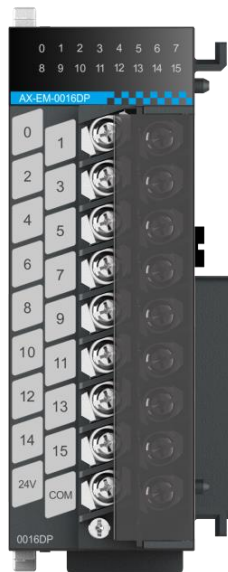

The terminal wiring is as follows:

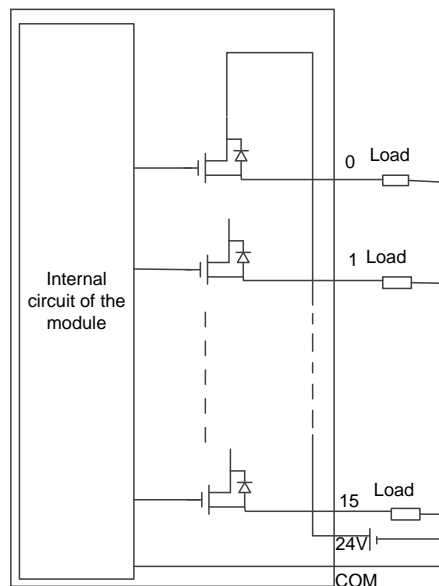

Figure 5.16 Terminal wiring

Note:

- The digital output module needs an external power supply for proper working.
- The module needs to be installed on a properly-grounded metal bracket, and the metal dome at the module bottom must be in good contact with the bracket.
- Do not bind the sensor cable together with the AC cable, main circuit cable, or high-voltage cable. Otherwise, the binding can increase noise, surge, and induction impact. When using shielded cables, use single-point grounding for the shield layer.

5.4.3 AX-EM-0016DN digital output module

The wiring terminals of AX-EM-0016DN digital output module are shown in the following figure. This module supports 16 digital outputs of the sink type, and uses an external 24VDC power supply.



The terminal wiring is as follows:

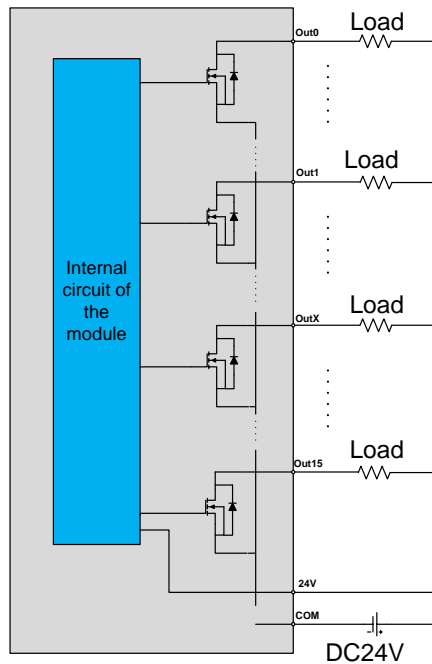

Figure 5.17 Terminal wiring

Note:

- The digital output module needs an external power supply for proper working.
- The module needs to be installed on a properly-grounded metal bracket, and the metal dome at the module bottom must be in good contact with the bracket.
- Do not bind the sensor cable together with the AC cable, main circuit cable, or high-voltage cable. Otherwise, the binding can increase noise, surge, and induction impact. When using shielded cables, use single-point grounding for the shield layer.

5.4.4 AX-EM-4AD analog input module

The wiring terminals of AX-EM-4AD analog input module are shown in the following figure. This module supports 4 inputs

of current or voltage, and uses internal 5V power supply without the connection to an external power supply.

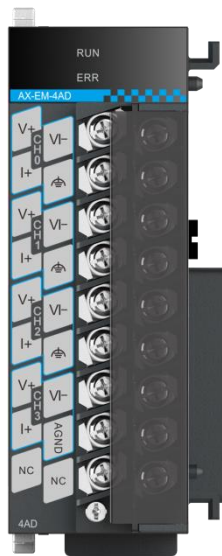

The terminal wiring is as follows:

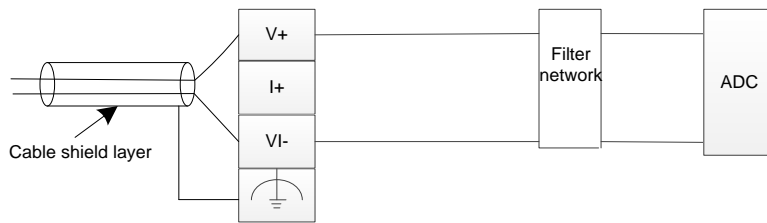

Figure 5.18 Wiring of voltage input

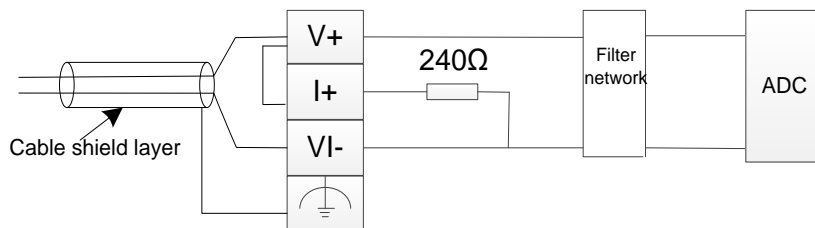

Figure 5.19 Wiring of current input

Note:

- For voltage input, use V+ and VI- for input, as shown in figure 5.15, and ensure the voltage input is within the range.
- For current input, connect V+ to I+ in short circuit mode, as shown in figure 5.16, and ensure the current input is within the range.
- The module needs to be installed on a properly-grounded metal bracket, and the metal dome at the module bottom must be in good contact with the bracket.
- Do not bind the analog input cable together with the AC cable, main circuit cable, or high-voltage cable. Otherwise, the binding can increase noise, surge, and induction impact. When using shielded cables, use single-point grounding for the shield layer.

5.4.5 AX-EM-4DA analog output module

The wiring terminals of AX-EM-4DA analog output module are shown in the following figure. This module supports 4 outputs of voltage or current, and uses an external 24VDC power supply.

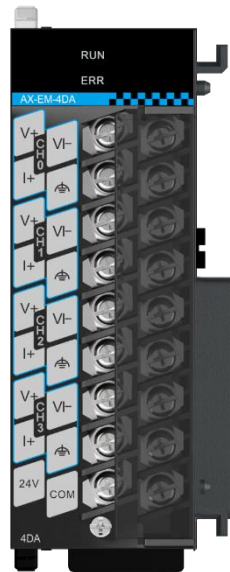

The terminal wiring is as follows:

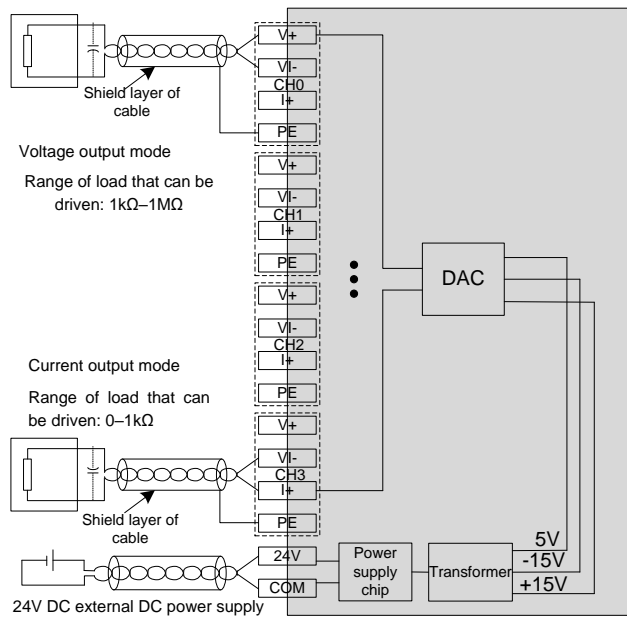

Figure 5.20 Terminal wiring

Note:

- Use the shielded two-core twisted-pair cable as the power cable.
- If there is noise or ripple in the external wiring, you can connect a capacitor with a capacitance of 0.1mF to 0.47mF and withstanding voltage of 25V between the V+/I+ terminal and the VI- terminal.
- The module needs to be installed on a properly-grounded metal bracket, and the metal dome at the module bottom must be in good contact with the bracket.
- Do not bind the analog output cable together with the AC cable, main circuit cable, or high-voltage cable. Otherwise, the binding can increase noise, surge, and induction impact. When using shielded cables, use single-point grounding

for the shield layer.

5.4.6 AX-EM-4PT temperature module

The wiring terminals of AX-EM-4PTC temperature module are shown in the following figure. This module supports measuring by using RTDs and TCs. When using RTDs for measuring, the 2-, 3-, and 4-wire systems are supported, and the internal 5V power supply is used for powering, without the need of connection to an external power supply.



The terminal wiring is as follows:

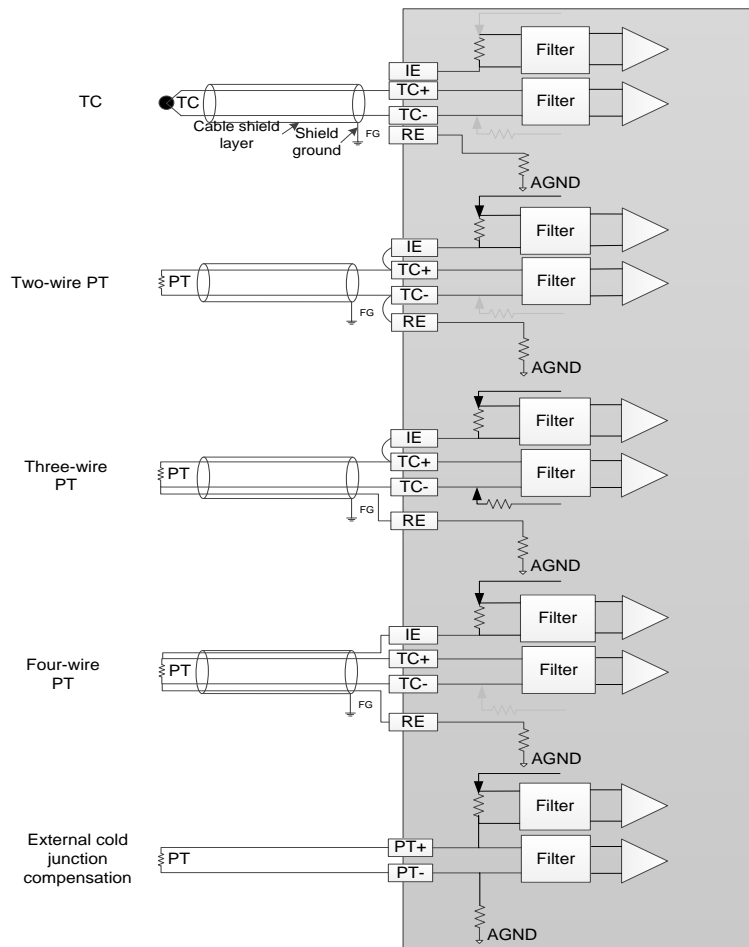

Figure 5.21 Terminal wiring

Note:

- When the PT resistor uses the two-wire system, connect IE to TC+ in short circuit mode and connect TC- to RE also in short circuit mode. In this situation, the cable resistance has an impact on the measuring accuracy.
- When the PT resistor uses the three-wire system, connect IE to TC+ in short circuit mode. In this situation, the cable resistance impact on the measuring accuracy is reduced to the minimum. (You are recommended to use the cable of which the three conductors have the same small resistance. Resistance inconsistency in the three conductors has an impact on the measuring accuracy.)
- When the PT resistor uses the four-wire system, the cable resistance almost has no impact on the measuring accuracy. This is the ideal wiring method.
- If the TC is used as the sensor, when a distance exists between the cold junction compensation and the TC end, the measured temperature is abnormal if no compensation conductor is used.
- If the TC is used as the sensor and internal cold junction compensation is configured, no external cold junction compensation resistor is needed. In this situation, the measuring accuracy may be affected since the module may have thermal accumulation. When multiple modules are connected to form a system, try to place the temperature module at the end of the rail to keep away from the CPU module.
- When the external cold junction compensation resistor is PT1000, shorten the PT resistor lead as much as possible, and place the PT resistor near user terminals.
- The module needs to be installed on a properly-grounded metal bracket, and the metal dome at the module bottom must be in good contact with the bracket.
- Do not bind the sensor cable together with the AC cable, main circuit cable, or high-voltage cable. Otherwise, the binding can increase noise, surge, and induction impact. When using shielded cables, use single-point grounding for the shield layer.

5.4.7 AX-EM-RCM-ET EtherCAT communication module

The wiring terminals of AX-EM-RCM-ET communication module are shown in the following figure. This module implements remote communication with the CPU module by using the EtherCAT protocol. In addition, the CPU module as the master node supports the expansion of up to 125 EtherCAT slave nodes. They use network cables as the transmission medium.

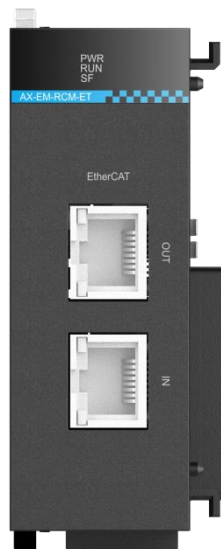

Note:

- When connecting the network cable, hold the crystal head of the cable and insert it into the RJ45 interface of the communication module until it makes a click sound. When removing the installed network cable, press the tail mechanism of the crystal head and pull out it from the module horizontally.
- Use shielded twisted-pair cables of category 5 or higher, plastic injection molded and iron shelled. The network cables in AX series options are recommended.

Option	Model	Specifications
Shielded cable for communication	AX-L3-20	Shielded cable for communication, L=2m; AX-L3-20; RoHS
Shielded cable for communication	AX-L3-50	Shielded cable for communication, L=5m; AX-L3-50; RoHS

If you make the communication cables by yourself, the signal pins of the cables are distributed as follows:

Pin	Signal	Signal direction	Signal description
1	TD+	Output	Data transmission +
2	TD-	Output	Data transmission -
3	RD+	Input	Data receiving +
4	--	--	Unused
5	--	--	Unused
6		Input	Data receiving -
7	--	--	Unused
8	--	--	Unused

If you make the communication cables by yourself, ensure the cables meet the following requirements:

- Length requirements: Fast Ethernet requires that the length of the cable between equipment cannot exceed 100 meters when you use the EtherCAT bus. If the length exceeds 100 meters, signal is attenuated, and communication is impacted.
- Technical requirements: The communication cables you use must pass the conductivity test 100%, without short circuit, opened circuit, dislocation or poor contact.
- To prevent the communication cable from being affected by other tensions and ensure the stability of communication, fix the cable close to the equipment side before communication.

6 Programming tool

The programmable controller uses the programming tool Invtmatic Studio developed by Shenzhen INVT Electric Co. Ltd. Invtmatic Studio is a powerful programming tool, supporting the IL, ST, FBD, LD, CFC, and SFC programming languages compliant with IEC61131-3 standards. Please visit www.invt.com to download the installation package of the programming tool.

6.1 Invtmatic Studio introduction

Invtmatic Studio is widely used in energy, transportation, municipal, metallurgy, chemical, pharmaceutical, food, textile, packaging, printing, rubber and plastics, machine tools and military industries. It provides an open and fully integrated programming development environment with advanced technology and powerful functions for project development that is based on programming languages compliant with IEC 61131-3.

6.2 Software obtaining and installation requirements

(1) Software obtaining

Invtmatic Studio is free software. To obtain the installation files and related reference materials, do as follows:

Visit www.invt.com, choose **Support** > **Download** > **Software**, and then download the software.

(2) Software installation requirements

You can install the software on a computer or desk:

- Installed with Windows XP/Windows 7/Windows 8/Windows 10
- CPU clock speed: 2GHz or higher
- Memory: 2GB or higher
- Available hardware space: 5GB or higher

6.3 Software installation and uninstallation

(1) Preparing

If it is the first time to install Invtmatic Studio, check whether your computer meets the software installation requirements. If yes, you can install it directly.

If you want to install the latest version of Invtmatic Studio, check the version information about the installed software by choosing **Help** > **About**. If it is not the latest version, you can upgrade the software using the online upgrade method.



(2) Installing the software

Step 1 Locate the installation file storage path, double-click **Invtmatic Studio Setup 64 V1.0.2.exe**.

The installation starts. See the following figure.

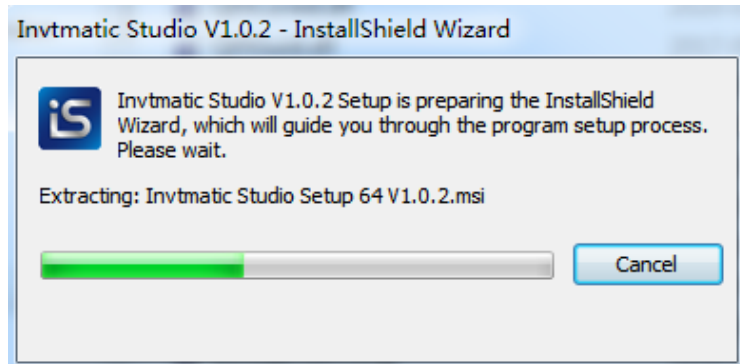

Step 2 When the dialog box shown in the following figure appears, click **Next**.

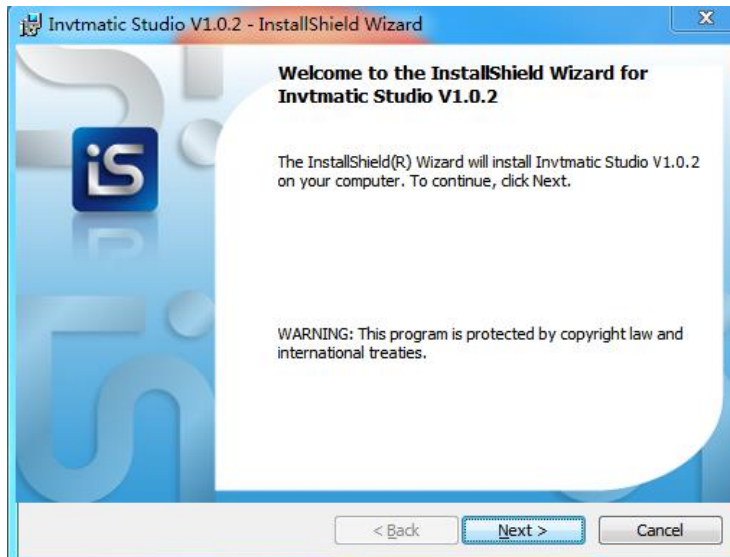

Step 3 Then the license agreement dialog box appears. Select **I accept the terms in the license agreement**, and then click **Next**.

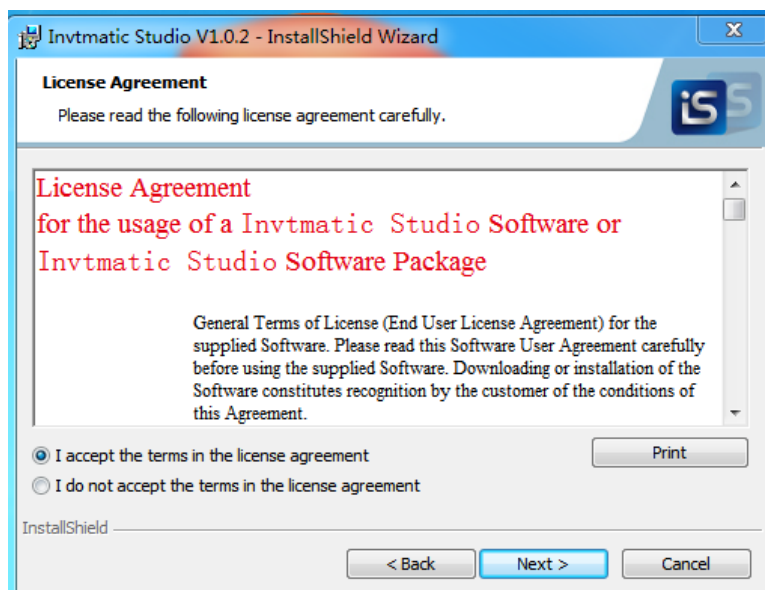

Step 4 Set the software installation path, and click **Next**.

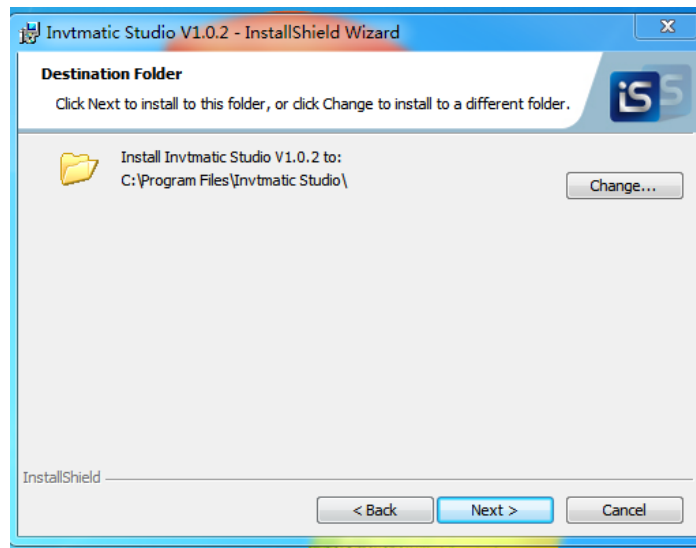

Step 5 The installation component selection interface appears. Select an installation option. If you have no special requirement, keep the default selection, and click **Next**.

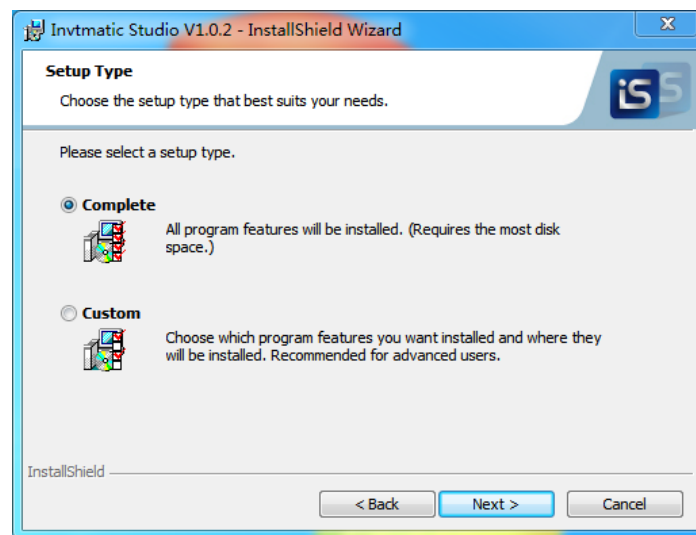

Step 6 When the following interface appears, click **Install**.

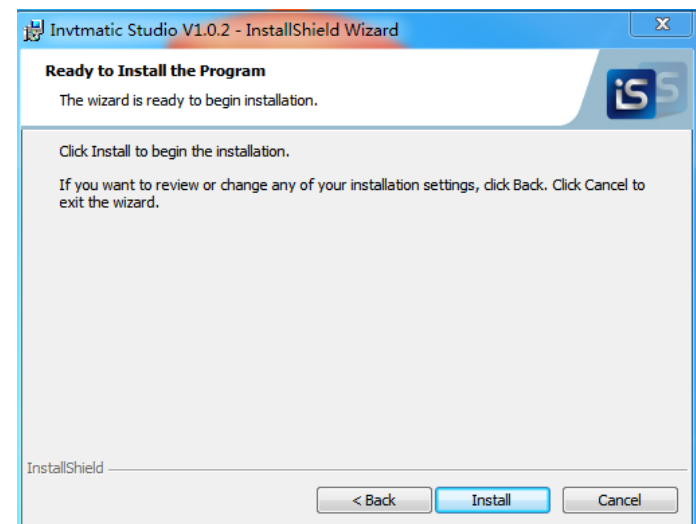

Step 7 An installation progress bar appears. Click **Finish** when the installation is completed.

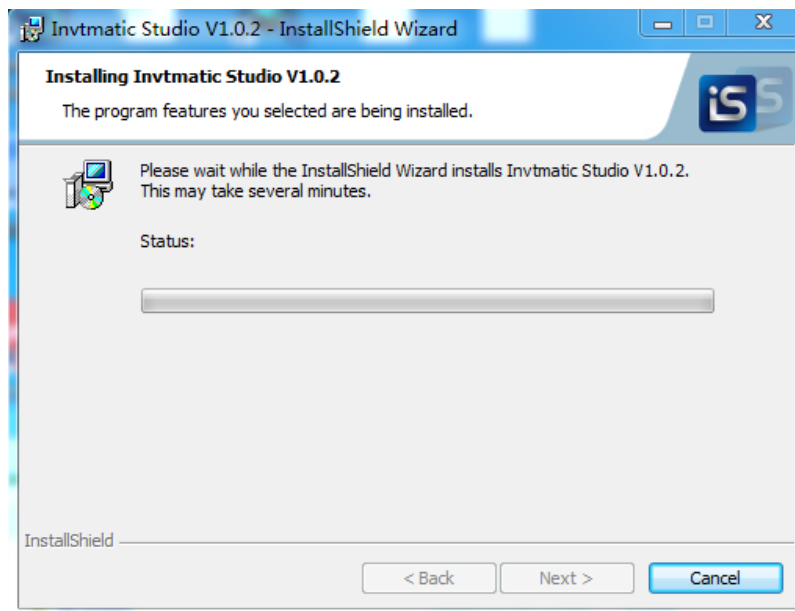
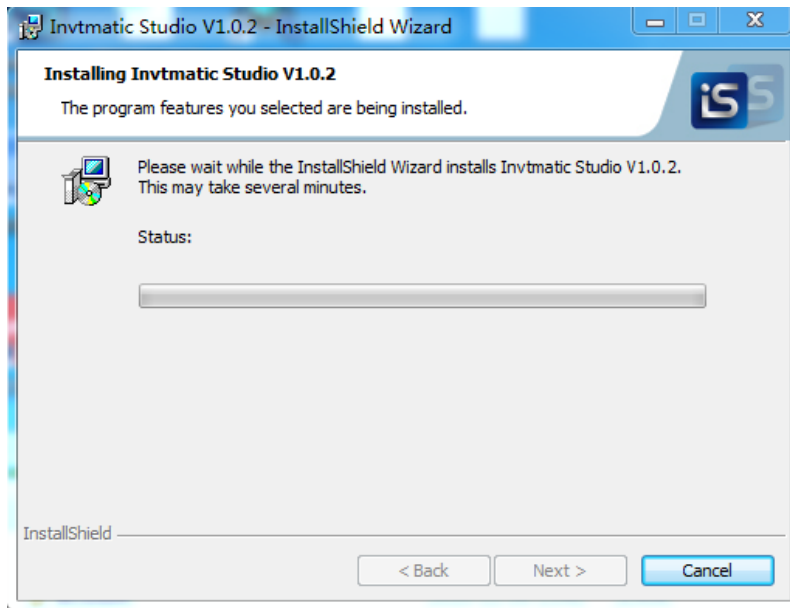

(3) Uninstalling the software

You can uninstall Invtmatic Studio by using the standard software uninstallation method of a Windows system. The procedure is as follows:

- Step 1 Shut down Invtmatic Studio running programs, including the backend running program.
- Step 2 Enter the control panel, find and right-click Invtmatic Studio, and click **Uninstall**.
- Step 3 Wait until the software is uninstalled.

6.4 Connecting AX7□-C-1608□ programmable controller to a PC

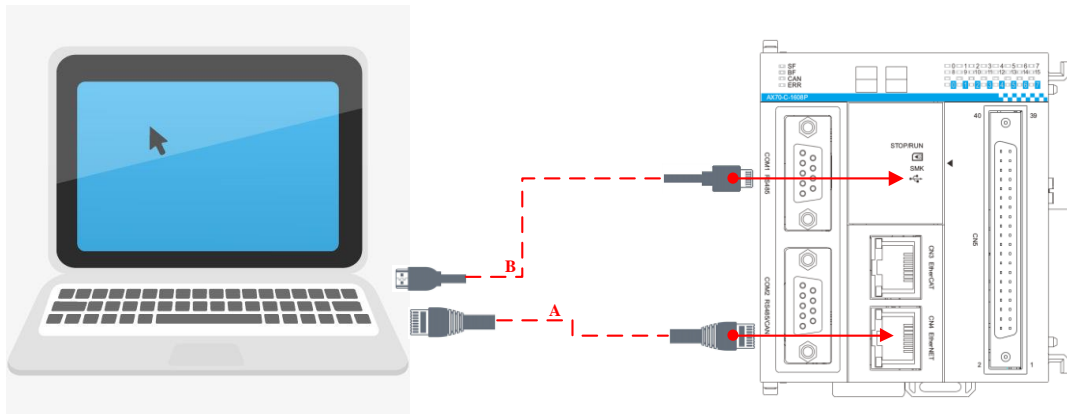

The hardware connection between an upper computer and programmable controller:

- Method A: Using a Mini USB cable
- Method B: Using a LAN network cable

6.5 How to use the programming software

Step 1 Start the programming environment.

Step 2 Double-click the software icon of Invtmatic Studio. The programming environment is as follows:

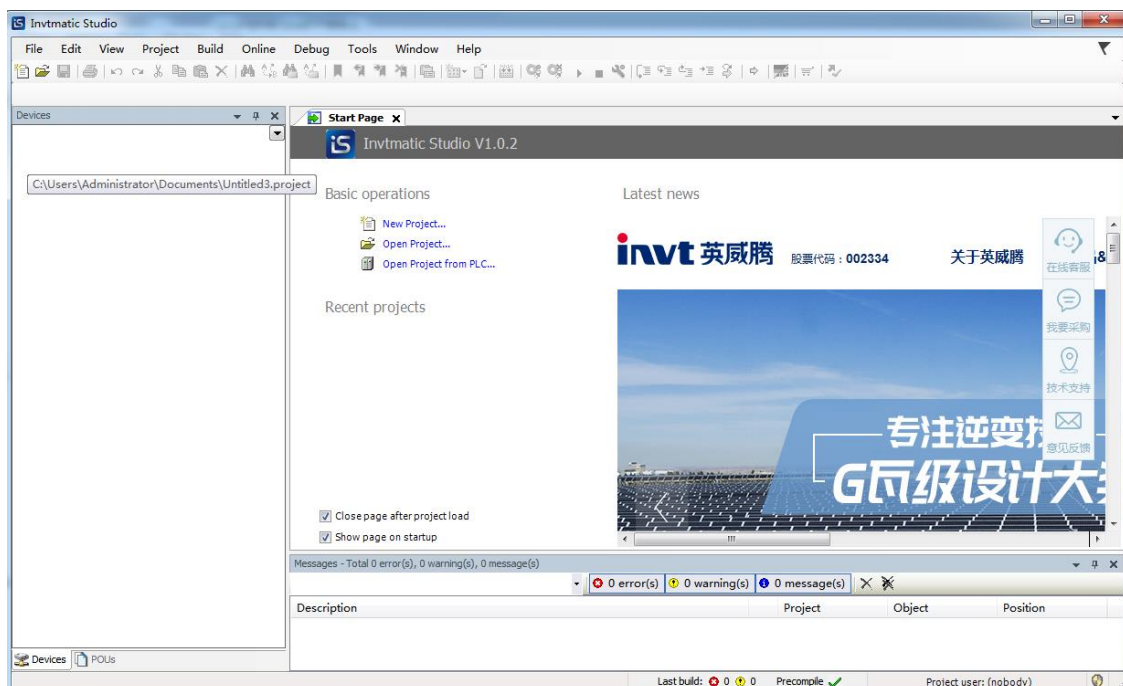

Step 3 Choose **Tools > Device repository** to add a device profile.

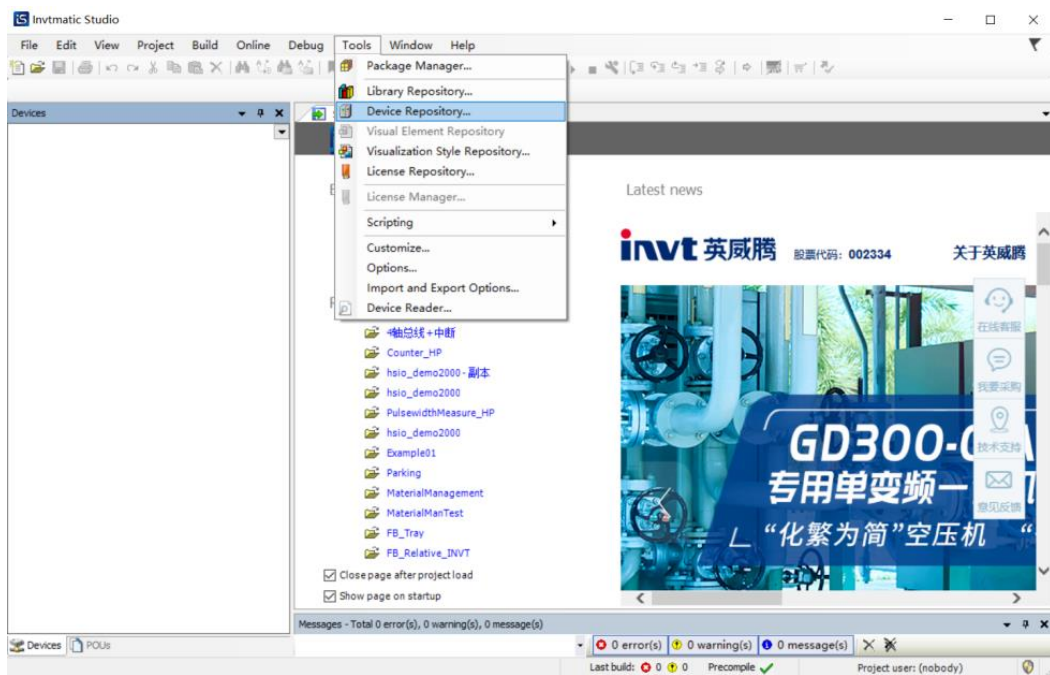

Step 4 In the **Device repository** pop-up window, click **Install**.

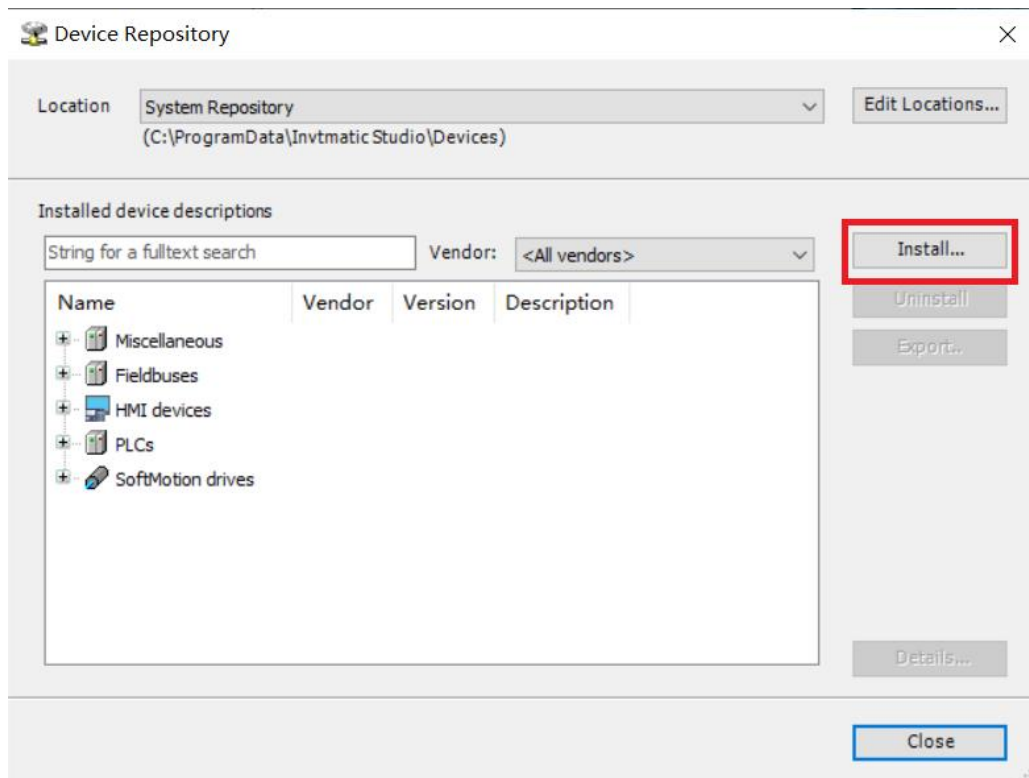

Step 5 From the **Install device profile** window, select the device profile to be installed from a local folder and then click **Open**.

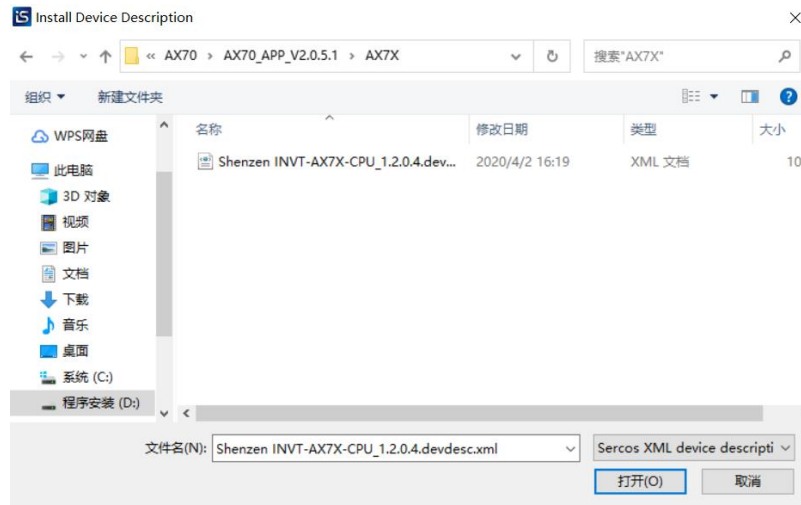

Step 6 Click the project creation icon  at the upper left corner or choose **File > New Project**, or directly click **New Project** in the window to quickly create a project. Select the project category, template, save path and file name, as shown in the following figure.

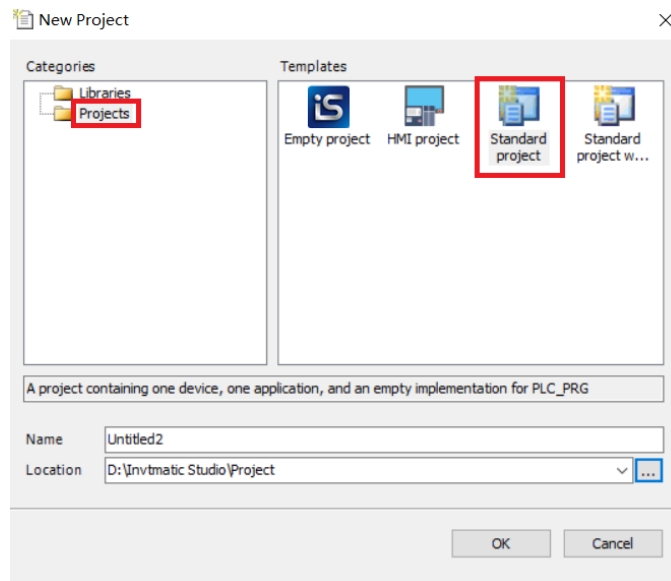

Step 7 Click **OK**. On the standard project setting interface that appears, select the device type and programming language. See the following figure.

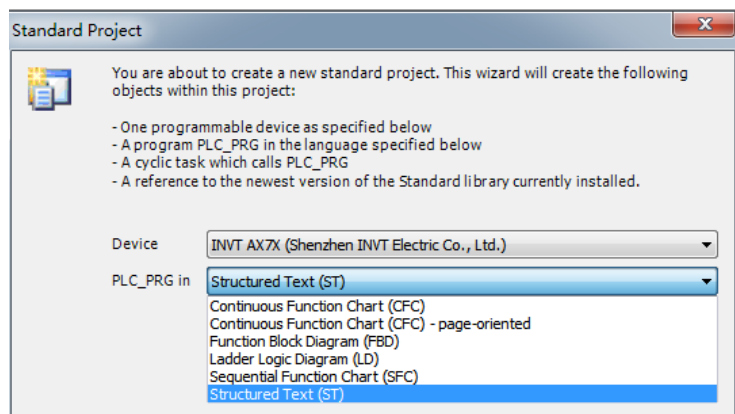

Step 8 On the configuration and programming interface, double-click **PLC_PRG(PRG)** to write programs. See the following figure.

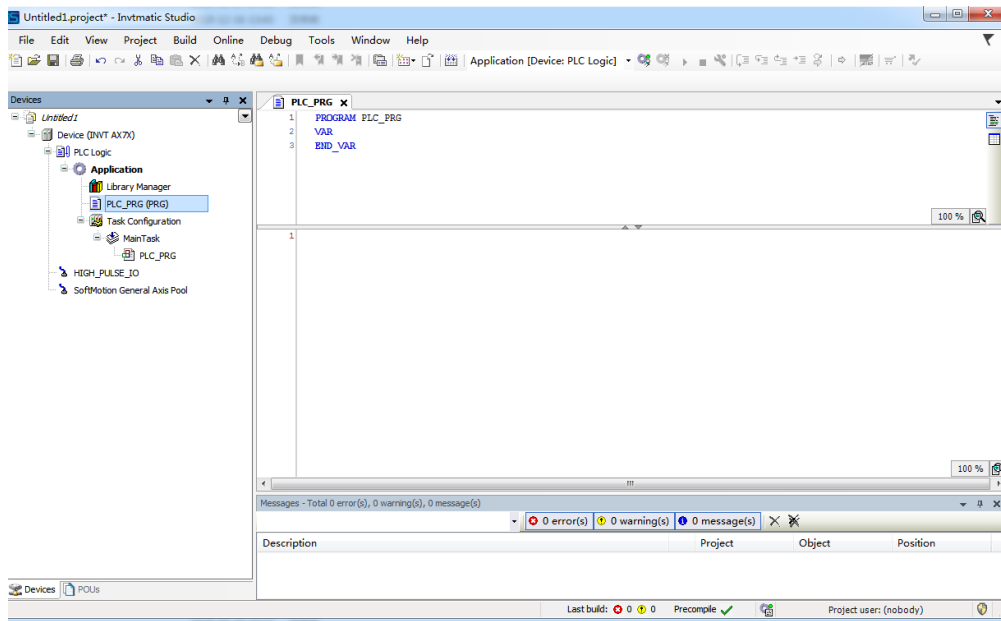

7 Maintenance and inspection

7.1 Startup and shutdown

After programs are written to the CPU module, you can perform startup and shutdown.

When you need to run the system, turn the RUN/STOP switch to the RUN position and ensure that the RUN indicator is on. When you need to stop running, turn the RUN/STOP switch to the STOP position.

Note: When the RUN/STOP switch is turned to the RUN position, you can use the upper computer backend to run or stop the system. When the RUN/STOP switch is turned to the STOP position, you cannot use the upper computer backend to run the system. Therefore, if the CPU is hung or programs cannot be downloaded due to incorrect programming on the upper computer, you can turn the RUN/STOP switch to the STOP position and re-power on the system to download or debug programs again.

7.2 Indicator and SMK description

7.2.1 LED fault indicator

The fault indicators of the programmable controller are divided into system and bus indicators and high-speed I/O indicators.

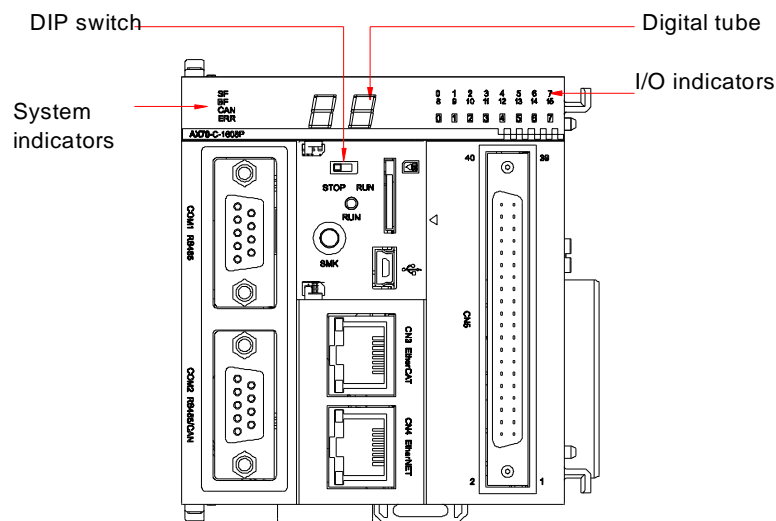

Table 7.1 System and bus fault indicators

Fault indicator	Fault type
SF	System fault.
BF	Bus communication fault.
CAN	CAN bus fault indicator.
ERR	Module fault.

Note: When multiple programmable controllers are connected, you can click the **Wink** button on the software platform to check the status of the SF, BF, CAN and ERR indicators to identify equipment.

High-speed I/O indicators: If the I/O of a port is at a high level, the corresponding indicator is on, and if the I/O is at a low level, the corresponding indicator is off.

7.2.2 SMK key

The main function of the SMK key is to restore the CPU module IP address (rP), and clear application programs (cA). The default CPU module IP address is 192.168.1.10. If you want to restore the default address from a modified IP address, you can operate the SMK key for restoring. The operation method is as follows:

Set the CPU module to the STOP state. Press the SMK key first, and then press and hold it when the digital tube displays "rP" (reset IP). The digital tube displays "rP" and turns off alternately (rp→pand turns), indicating that the IP address restoring is being performed. Release the SMK key when the digital tube is steadily off, indicating IP address restoring success. Then the digital tube restores to display "rP". Press the SMK key until the digital tube displays 00 (rP→cA→rU→rP).

If you release the SMK key in the process of displaying "rP" and turning off alternatively, the IP address restoring operation is cancelled, and the digital tube restores to display "rP".

If you want to clear an application program from the CPU module, the method is as follows:

Press the SMK key first, and press and hold the SMK key when the digital tube displays "cA". The digital tube displays "rP" and turns off alternately (rp→Off→rP→Off), indicating that the program clearing is being performed. Release the SMK key when the digital tube is steadily off. Power off and restart the CPU module. Then the program is cleared successfully.

7.2.3 Daily inspection

No.	Check item	Check criteria	Handling method
1	Exterior inspection	Visually check for dirt accumulation.	Clean dust and dirt.
2	DIN rail installation	Check whether the DIN rail is reliably fixed to the installation plane.	Fix the DIN rail firmly.
3	Module installation	Check whether modules are reliably installed on the DIN rail.	Install the modules securely.
4	Connection between modules	Check whether the locks between modules are in place and whether the connection is firm and reliable.	Ensure the connection is reliable.
5	Loose terminals	Check for loose terminals.	Connect terminals securely.
6	Cable connection ports	Check whether cable connection ports are firm and reliable.	Connect terminals securely.
7	Indicators/digital tube	Check whether indicators/digital tube displays status correctly.	Ensure that indicators/digital tube displays status correctly.

7.2.4 Periodic maintenance

No.	Check item	Check criteria	Handling method
1	Ambient environment	Use a thermometer and hygrometer to check whether the environment temperature/humidity meets the specifications of each module.	Locate the exception cause and handle the exception in time.

No.	Check item	Check criteria	Handling method
2	Air	Measure corrosive gas.	Find out the source of the gas and handle it properly to meet the operating environment requirements.
3	Power supply voltage	Check whether the input AC power meets the input specifications of the power supply module.	Ensure that the power supply system meets the requirements.
4	Installation	Check whether modules are installed reliably and securely.	Ensure that correct methods are used.
5	Loose terminal screws	Check whether screws are loose with a screwdriver.	Fasten terminal screws.
6	Programmable controller diagnostic logs	Check error records.	See the troubleshooting section in the software manual.

Note: Carry out daily inspection and periodic maintenance for equipment that has been relocated or modified or has suffered collision.

7.3 Digital tube display of the CPU module

If programs have no fault after download, the digital tube of the CPU module displays "00" steadily.

If a program has a fault, the digital tube displays the fault information in blinking way.

For example, if only fault 19 occurs, the digital tube displays "19" and turns off alternately. If fault 19 and fault 29 occur simultaneously, the digital tube displays "19", turns off, displays "29", and turns off alternately. If more faults occur simultaneously, the display way is similar.

Appendix A Wiring examples

A.1 AX7□-C-1608□ high-speed I/O

A.1.1 Input wiring example of CH0–CH5

High-speed I/O CH0–CH5 support single-ended and differential signal input, and do not share common terminals. The following takes encoder connection as an example to describe the high-speed I/O interfaces and wiring methods when the output interface types are NPN, PNP, push-pull and differential respectively.

- 1) When the encoder output interface type is NPN, the wiring method is as follows:

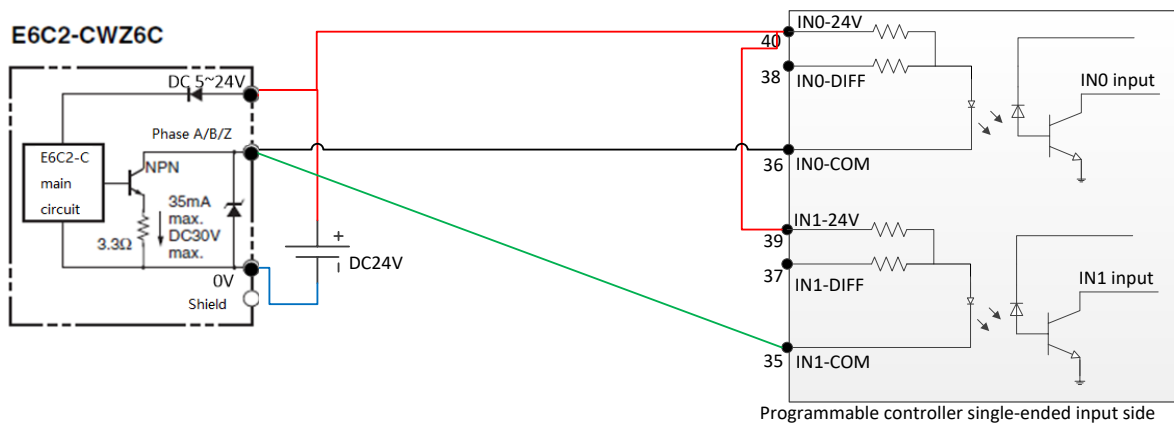

The preceding figure shows that phases A and B of the encoder whose output interface type is NPN are respectively output to CH0 and CH1 of the programmable controller CPU module.

- 2) When the encoder output interface is PNP, the wiring method is as follows:

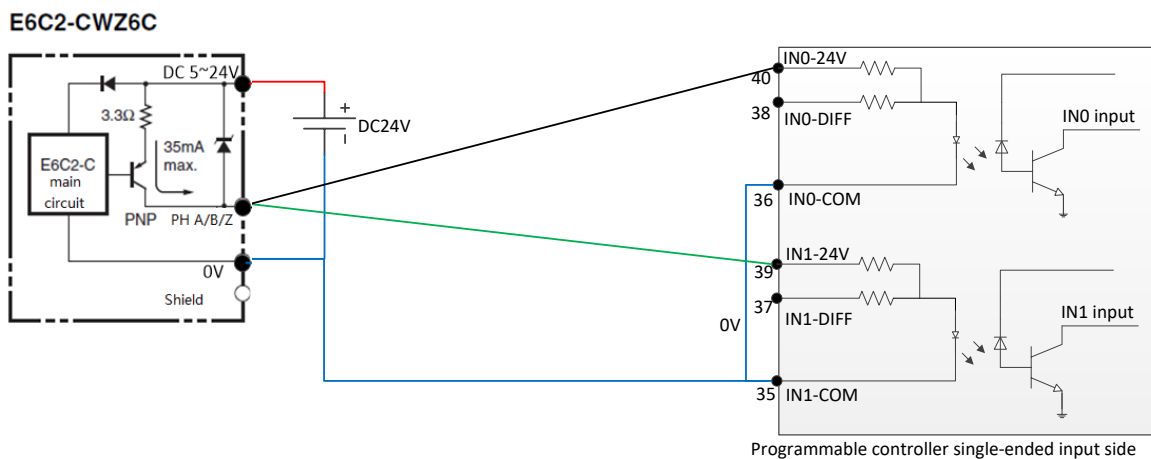

The preceding figure shows that phases A and B of the encoder whose output interface type is PNP are respectively output to CH0 and CH1 of the programmable controller CPU module.

- 3) When the encoder output interface type is push-pull, the wiring method is as follows:

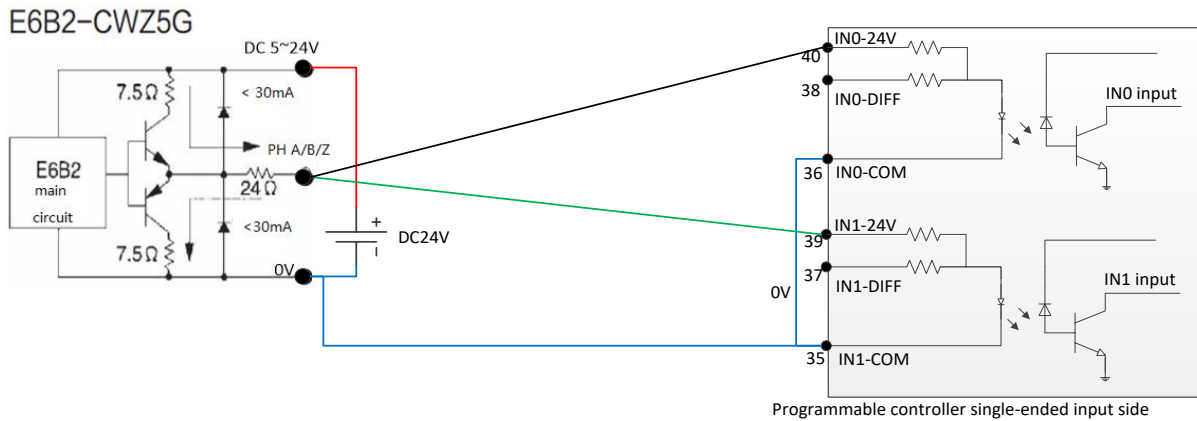

The preceding figure shows that phases A and B of the encoder whose output interface type is push-pull are respectively output to CH0 and CH1 of the programmable controller CPU module.

4) When the encoder output interface type is differential, the wiring method is as follows:

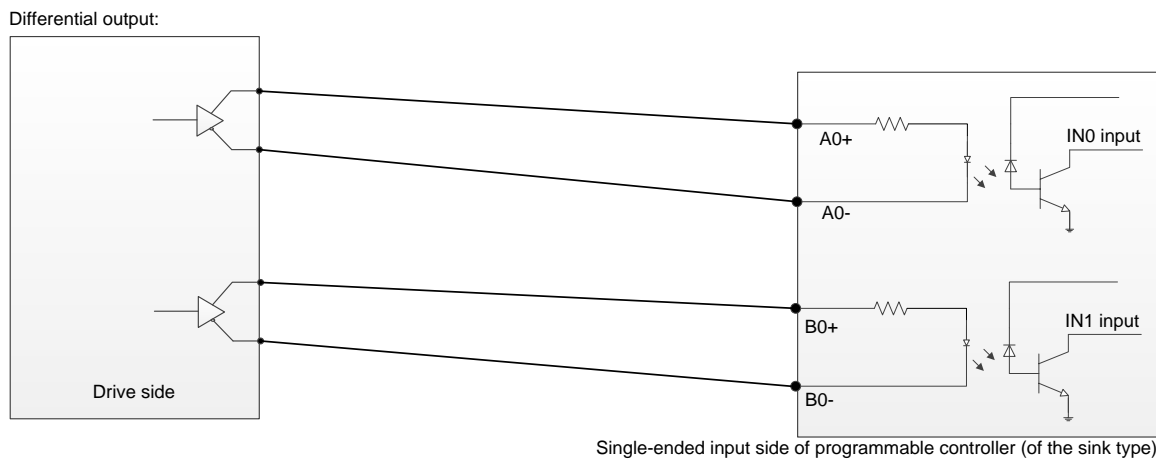
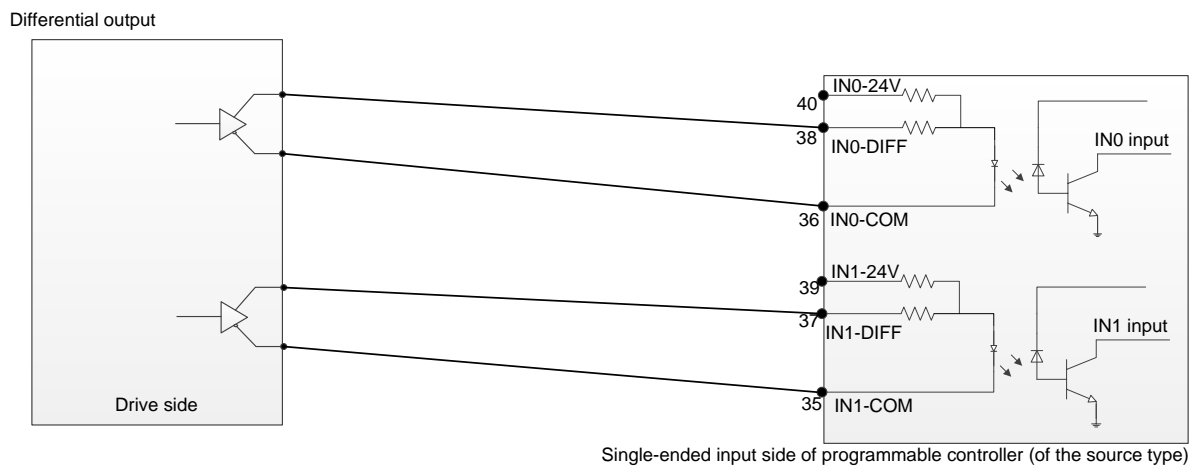

The preceding figures show that phases A and B of the encoder whose output interface type is differential are respectively output to CH0 and CH1 of the programmable controller CPU module.

It is recommended to use the encoder with differential signal output, which can further improve the anti-interference performance of the equipment in hostile environments.

A.1.2 Single-ended input wiring example of CH6–CH15

High-speed I/O CH6–CH15 support only single-ended signal input, among which CH6, CH8, CH10, CH12, and CH14 share common terminal SS1, while CH7, CH9, CH11, CH13, and CH15 share common terminal SS2. The following takes encoder connection as an example to describe the high-speed I/O interfaces and wiring methods when the output interface types are NPN, PNP, and push-pull respectively.

- 1) When the encoder output interface type is NPN, the wiring method is as follows:

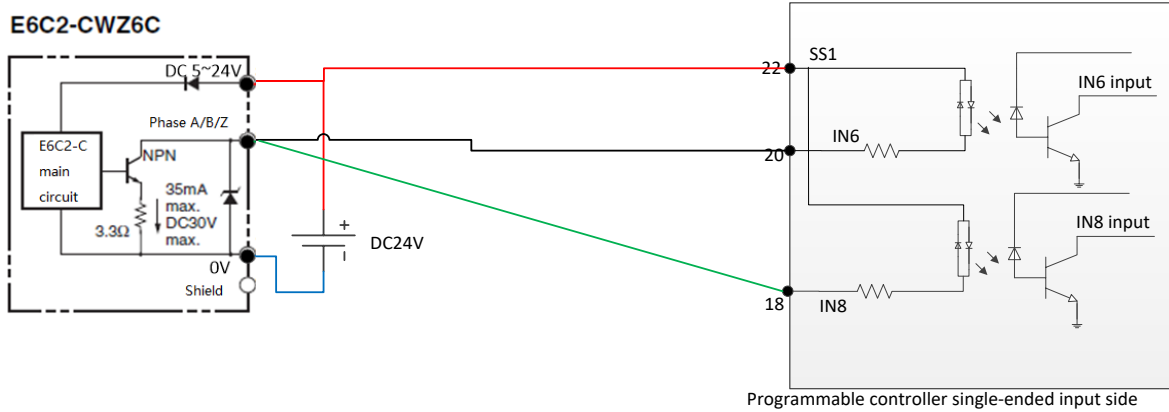

The preceding figure shows that phases A and B of the encoder whose output interface type is NPN are respectively output to CH6 and CH8 of the programmable controller CPU module.

- 2) When the encoder output interface type is PNP, the wiring method is as follows:

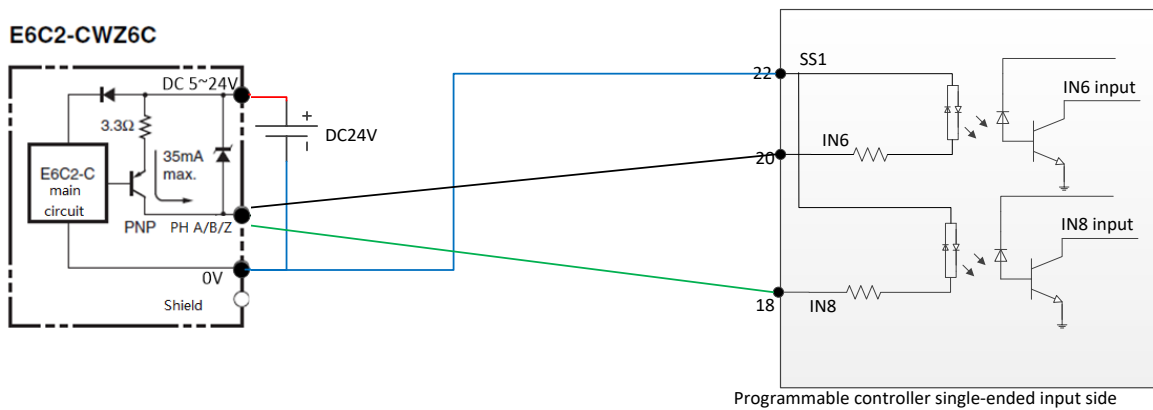

The preceding figure shows that phases A and B of the encoder whose output interface type is PNP are respectively output to CH6 and CH8 of the programmable controller CPU module.

- 3) When the encoder output interface type is push-pull, the wiring method is as follows:

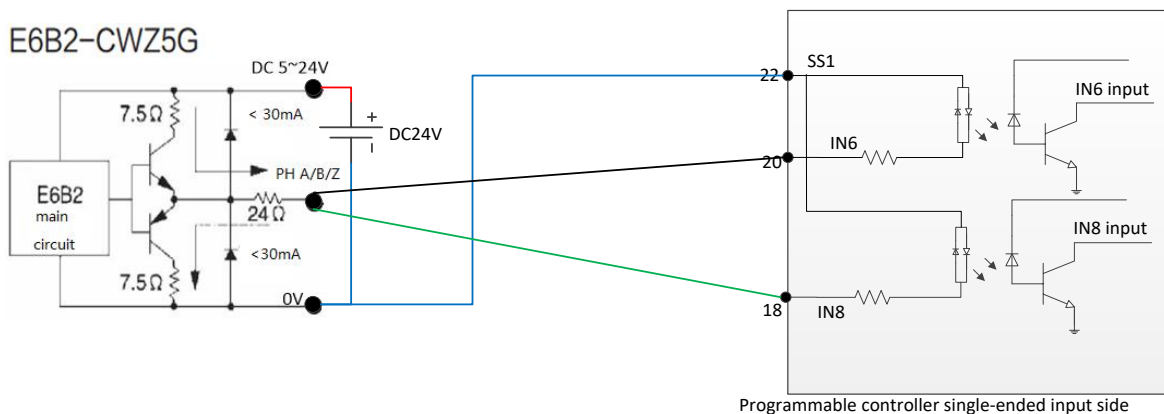

Note: The wiring method is similar to that for the encoder whose output interface type is PNP.

A.1.3 Output wiring example

There are 8 channels of high-speed output signal, supporting only single-ended output. OUT0, OUT2, OUT4, and OUT6 share common terminal COM1, while OUT1, OUT3, OUT5, and OUT7 share common terminal COM2. The following figure takes drive optocoupler as an example to describe the high-speed output interfaces and wiring methods.

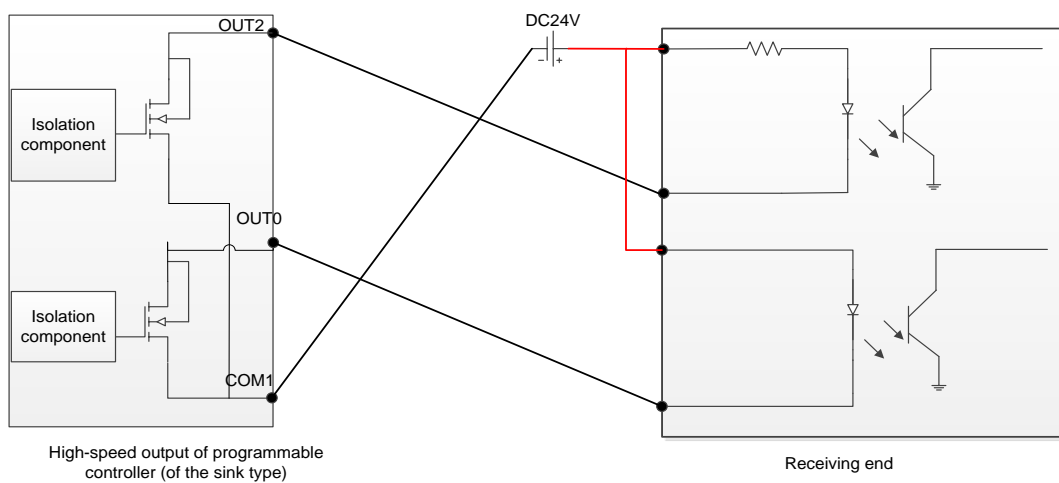
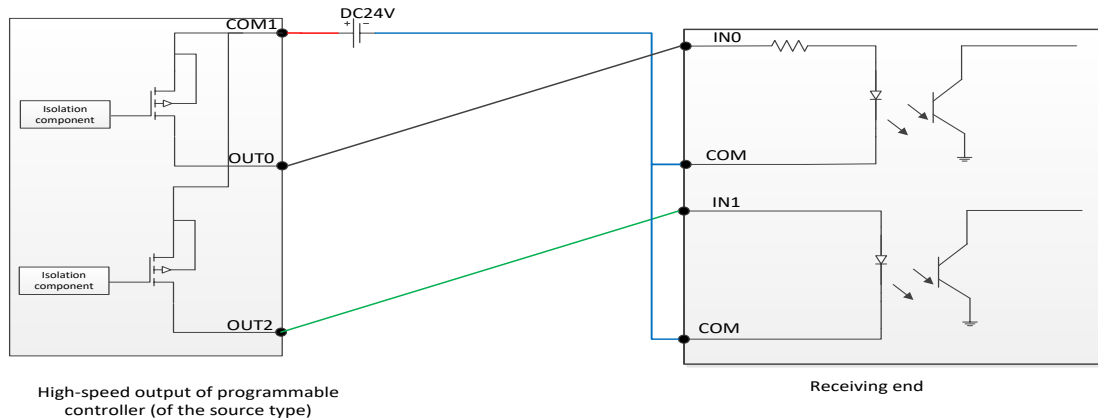

A.2 AX-EM-1600D digital input module

AX-EM-1600D digital input module has 16 inputs, sharing a common terminal. The following figure takes photosensor as an example to describe the wiring methods when the output interface types are NPN and PNP respectively.

- 1) When the photosensor output interface type is NPN, the wiring method is as follows:

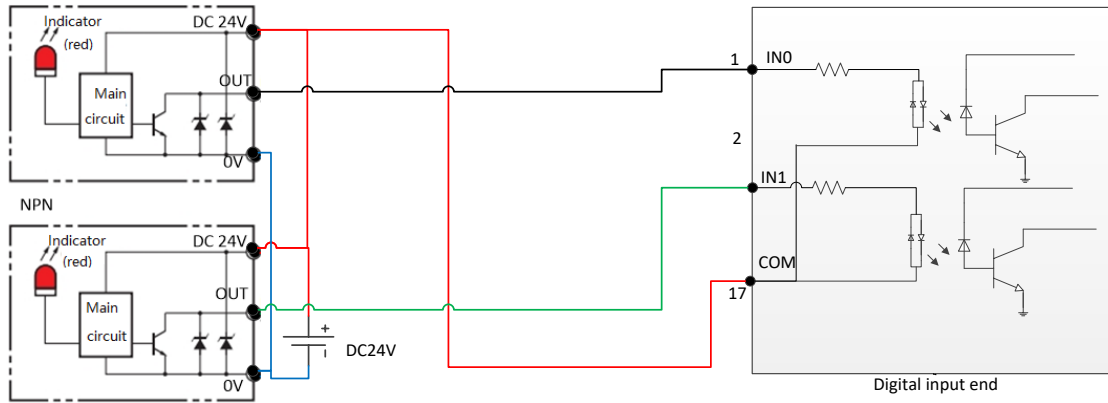

2) When the photosensor output interface type is PNP, the wiring method is as follows:

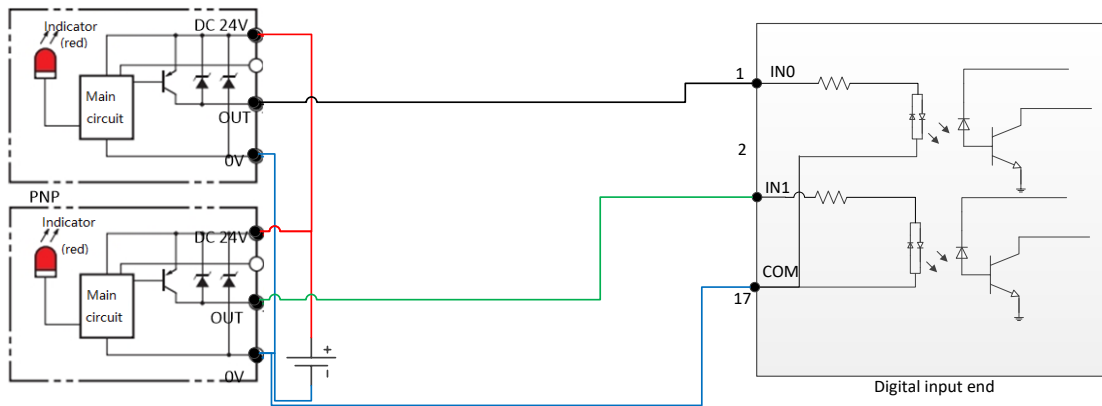

A.3 AX-EM-0016DP digital output module

AX-EM-0016DP digital output module has 16 outputs, sharing a common terminal. The following figure takes drive relay and optocoupler as an example to describe the wiring method.

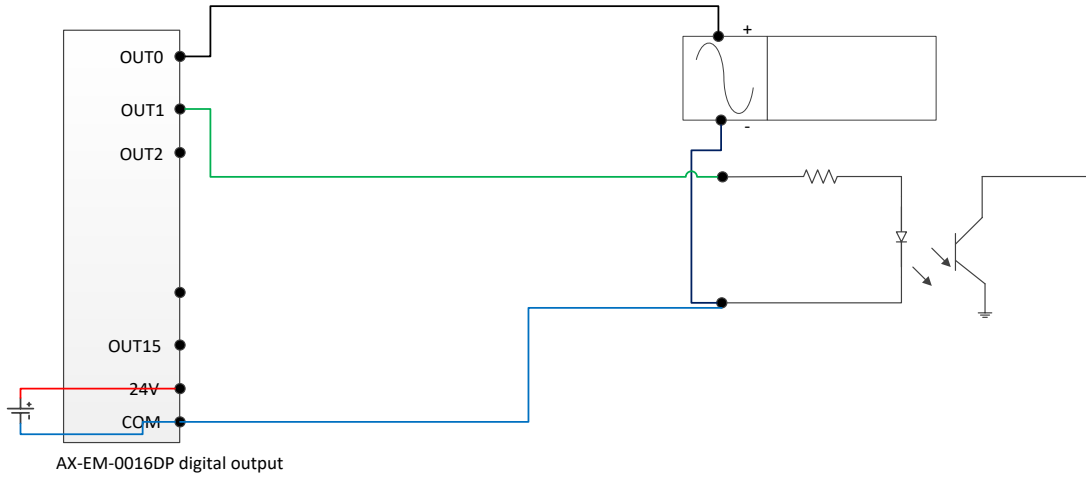

A.4 AX-EM-0016DN digital output module

AX-EM-0016DN digital output module has 16 outputs, sharing a common terminal. The following figure takes drive relay and optocoupler as an example to describe the wiring method.

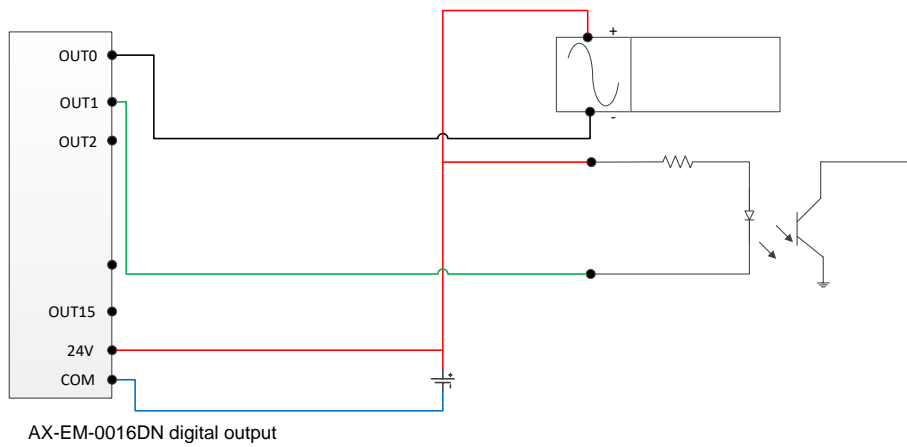



E-mail:overseas@invt.com.cn Website:www.invt.com

The products are owned by **Shenzhen INVT Electric Co.,Ltd.**

Two companies are commissioned to manufacture: (For product code, refer to the 2nd/3rd place of S/N on the name plate.)

Shenzhen INVT Electric Co.,Ltd. (origin code: 01)

Address: INVT Guangming Technology Building, Songbai Road,
Matian, Guangming District, Shenzhen, China

INVT Power Electronics (Suzhou) Co.,Ltd. (origin code: 06)

Address: No. 1 Kunlun Mountain Road, Science & Technology
Town, Gaoxin District, Suzhou, Jiangsu, China

Industrial Automation: ■ HMI

■ PLC

■ VFD

■ Servo System

■ Elevator Intelligent Control System

■ Rail Transit Traction System

Energy & Power:

■ UPS

■ DCIM

■ Solar Inverter

■ SVG

■ New Energy Vehicle Powertrain System

■ New Energy Vehicle Charging System

■ New Energy Vehicle Motor



6 6 0 0 1 - 0 0 7 5 0

Copyright© INVT.

Manual information may be subject to change without prior notice.

202212 (V1.1)